



**HAL**  
open science

## Full Power Constraints HiL Setup for Battery Module Testing in Electric Vehicles

Ronan German, Florian Tournez, Anatole Desreveaux, Alain Bouscayrol,  
Calin Husar, Marius Ciocan, Adrien Genic, Dragan Zuber

► **To cite this version:**

Ronan German, Florian Tournez, Anatole Desreveaux, Alain Bouscayrol, Calin Husar, et al.. Full Power Constraints HiL Setup for Battery Module Testing in Electric Vehicles. 2021 IEEE Vehicle Power and Propulsion Conference (VPPC 2021), Oct 2021, Gijon, Spain. 10.1109/vppc53923.2021.9699218 . hal-03701953

**HAL Id: hal-03701953**

**<https://hal.univ-lille.fr/hal-03701953>**

Submitted on 22 Jun 2022

**HAL** is a multi-disciplinary open access archive for the deposit and dissemination of scientific research documents, whether they are published or not. The documents may come from teaching and research institutions in France or abroad, or from public or private research centers.

L'archive ouverte pluridisciplinaire **HAL**, est destinée au dépôt et à la diffusion de documents scientifiques de niveau recherche, publiés ou non, émanant des établissements d'enseignement et de recherche français ou étrangers, des laboratoires publics ou privés.

# Full Power Constraints HiL Setup for Battery Module Testing in Electric Vehicles

Ronan German<sup>1</sup>, Florian Tournez<sup>1</sup>, Anatole Desreveaux<sup>1</sup>, Alain Bouscayrol<sup>1</sup>, Calin Husar<sup>2</sup>, Marius Ciocan<sup>2</sup>,  
Adrien Genic<sup>3</sup>, Dragan Zuber<sup>3</sup>

<sup>1</sup>Univ. Lille, Arts et Metiers Institute of Technology, Centrale Lille, Junia, ULR 2697 - L2EP, F-59000 Lille, France

<sup>2</sup>Siemens Industry Software SRL, Romania

<sup>3</sup>Typhoon HIL, Republic of Serbia

**Abstract-** The aim of this paper is to validate the compliance between an EV and a battery with a reference driving cycle. The Hardware in the Loop methodology is used. It is based on the interactions between the different EV subsystems. In this paper, a 35 kWh battery pack is studied. A 5 kWh module from this pack is tested with the same power constraints when used in the real EV. The developed power Hardware-in-the-Loop (HiL) test bench is composed of a model of the traction chain and a controllable current source. A driving velocity cycle is used as an input. The HiL test is achieved at full power scale for a module. It is shown that the tested battery could be used in the studied EV as the limits of the battery operation are not crossed for a WLTC velocity cycle.

**Keywords**—Hardware-in-the-Loop, Battery testing, Li-ion batteries, electric vehicle

## I. INTRODUCTION

The development of Electric Vehicles (EVs) is increased due to the fast battery improvements in terms of price [1] and energy density [2].

When a new battery is intended to be integrated as a subsystem into an Electric Vehicle (EV), different tests are performed. EV simulation [3] can be a first step (for example the battery sizing can be pre-validated). Full power tests are required to validate the compatibility using various experimental variables (temperature, voltage, current...).

Some power tests are performed by applying a recorded current cycle to the tested battery [4]. Nevertheless, such a method does not consider that the current from the traction is influenced by the battery voltage [5].

In this paper, the HiL method is used [6]. The objective of this paper is to test a real battery module at full power scale in interaction with the real-time simulation of the traction subsystem. The experimental measures are used as inputs of the traction model. The current applied to the battery is generated in interaction with these measures.

At first, the studied vehicle and the battery are presented. Then, the vehicle model is organized using the Energetic Macroscopic Representation (EMR) [7]. The control of the velocity is achieved. The vehicle is simulated for pre-validation. Finally, the full power HiL test is performed on a module which is a part of the studied battery.

## II. VEHICLE SIMULATION

### A. Presentation of the tested battery

The reference vehicle is a Renault Zoe (Fig. 1). This is a compact vehicle (1500 kg) with a -full electrical traction (65 kW). As the traction is only electrical, the battery is the most critical subsystem. Different battery size have been used since 2012 (from 20 kWh to 50 kWh).

In this paper, a 35 kWh Li-ion battery (NMC) is tested for integration in the Renault Zoe. It is composed of 7 modules produced by Bluways. These new modules are chosen for their high power and energy densities (1.9 kW/kg and 142 Wh/kg) which make them versatile for EVs but also plug in hybrid vehicles. They are mounted in series (Fig. 2). Each module stores 5 kWh of energy and has a nominal voltage of 55 V. The battery nominal voltage is 385 V. The module and the battery have the same capacity (80 Ah). The tested battery is slightly lighter (-10 kg) and has higher power capabilities (x5) compared to the original Zoe one despite a slightly lower energy (-5 kWh). The goal is to reduce the losses in the battery.

A battery is an energy storage system based on ions and chemical reactions [8]. As a consequence, it should be operated safely within temperature, voltage and current limits [9].

Table 1 gives those limits for the studied battery, deduced from the module and the architecture of the pack. The battery is designed to operate between 441 V and 287 V. The peak discharge current is 1200 A for 10 s and the maximal recharge current is 240 A. This recharge current is only possible between 5°C and 55°C. Under 5°C, the recharge current must be limited to avoid Lithium plating.

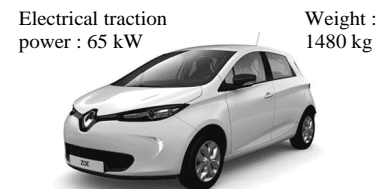

Fig. 1 Simplified characteristics of the Renault Zoe

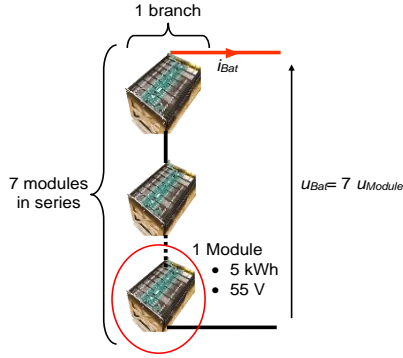

Fig. 2 Battery pack to be tested for Renault Zoe

Table 1 Battery operation limits

	Battery	Module
Voltage high	441 V	63 V
Voltage low	287 V	41 V
Current discharge	1200 A	1200 A
Current charge	- 240 A	- 240 A
Temperature high		55 °C
Temperature low (full power)		5 °C

### B. Structural scheme and EMR for the studied EV

Fig. 3 presents the structural scheme of the EV. It is composed of a battery which is the energy source. The electric drive is composed of a synchronous machine, the inverter and associated torque control. An equivalent wheel is used. It applies the traction force to the vehicle mass. A mechanical brake is also considered. Fig. 4 presents the Energetic Macroscopic Representation (EMR) of the studied EV. EMR is a representation of complex multi-physical models. It is based on power transfers, physical causality and pictograms representing functions (see Annex A). Equations (1-12) give the equations inside the Fig. 4 pictograms. Variables used are presented in Table 2 and the value of the parameters is given in Table 3. Equation (12) explains the braking strategy. When the total force is positive (traction) no mechanical brake is needed. When the traction force is negative the braking is 40 % mechanical (60 % of energy recovery) because of the mass distribution.

The EV model has been validated in [10] with experimental variables recorded in a real Renault Zoe. This model is available on the Simcenter Amesim cloud [11]. This cloud is an online simulation service including libraries of system (EVs for instance) and subsystem models.

Table 2 EV model variables

Name	Symbol	Unit
Battery Open circuit voltage	$OCV_{Bat}$	[V]
Battery state of charge	$SoC_{Bat}$	[%]
Battery current	$i_{Bat}$	[A]
Battery voltage	$u_{bat}$	[V]
Electric drive torque	$T_{ed}$	[Nm]
Electric drive rotation speed	$\Omega_{ed}$	[rad/s]
Torque at the wheels	$T_{wh}$	[Nm]
Rotation speed of the wheels	$\Omega_{wh}$	[rad/s]
Vehicle velocity	$v_{Veh}$	[rad/s]
Forces for wheels, brake and road resistance (friction+ aero+ slope)	$F_{Wh, br, res}$	[Nm]
Mechanical brake repartition	$k_{br}$	No unit

Table 3 EV model parameters

Name	Symbol	Value [unit]
Battery equivalent series resistance	$R_{bat}$	80 [mΩ]
Electric drive efficiency	$\eta_{ed}$	0.85
Gearbox ratio	$k_{gb}$	9.84
Gearbox efficiency	$\eta_{gb}$	0.97
Radius of the wheels	$R_{wh}$	0.25 [m]
Vehicle mass	$M_{veh}$	1480 [kg]
Road friction	$F_0$	200 [N]
Aerodynamic coefficient	$k_{Aero}$	0.9 [Ns <sup>2</sup> m <sup>-2</sup> ]

$$u_{bat} = OCV_{Bat}(SoC_{Bat}) - R_{bat}i_{bat} \quad (1)$$

$$\begin{cases} T_{ed} = T_{ed,ref} \\ i_{bat} = \frac{T_{ed}\Omega_{ed}\eta_{ed}^{k_{ed}}}{u_{bat}} \text{ with } k_{ed} = \begin{cases} 1 \text{ if } T_{ed}\Omega_{ed} < 0 \\ -1 \text{ if } T_{ed}\Omega_{ed} \geq 0 \end{cases} \end{cases} \quad (2)$$

$$\begin{cases} T_{wh} = k_{gb}T_{ed}\eta_{gb}^{k_g} \text{ with } k_g = \begin{cases} 1 \text{ if } T_{ed}\Omega_{ed} \geq 0 \\ -1 \text{ if } T_{ed}\Omega_{ed} < 0 \end{cases} \\ \Omega_{ed} = k_{gb}\Omega_{wh} \end{cases} \quad (3)$$

$$\begin{cases} F_{wh} = \frac{k_{diff}T_{wh}}{R_{wh}} \\ \Omega_{wh} = \frac{k_{diff}v_{veh}}{R_{wh}} \end{cases} \quad (4)$$

$$F_{tot} = F_{wh} + F_{br} \quad (5)$$

$$M_{veh} \frac{dv_{veh}}{dt} = F_{tot} - F_{res} \quad (6)$$

$$F_{res} = F_0 + K_{aero} \cdot v_{veh}^2 + F_{slope} \quad (7)$$

$$F_{tot,ref} = (v_{veh,ref} - v_{veh}) \cdot C(s) + F_{res} \quad (8)$$

$$\begin{cases} F_{br,ref} = k_{br} \cdot F_{tot,ref} \\ F_{wh,ref} = (1 - k_{br}) \cdot F_{tot,ref} \end{cases} \quad (9)$$

$$T_{wh,ref} = R_{wh} \cdot F_{wh,ref} \quad (10)$$

$$T_{ed,ref} = \frac{T_{wh,ref}}{k_{gb}} \quad (11)$$

$$k_{br} = \begin{cases} 0 \text{ if } F_{tot,ref} \geq 0 \\ 0.6 \text{ if } F_{tot,ref} < 0 \end{cases} \quad (12)$$

### C. Simulation results for a WLTC

The class 3 Worldwide Harmonized Light Vehicles Test Cycle (WLTC) is used as a reference velocity (Fig. 5). This cycle is interesting for EV batteries testing as it contains different road conditions (urban, extra-urban, highway).

Fig. 6 to Fig. 8 give the simulation results for the vehicle model with the tested battery parameters (Fig. 2).

The vehicle is simulated on Simcenter Amesim using a cloud service.

The simulated current is increasing with the EV velocity (Fig. 6) but the current stays within the normal operation limits (see Table 1). This is the same for the simulated battery voltage. The battery SoC decreases by 12.5% for the total distance of the WLTC (23 km). Thus, the estimated WLTC driving range with the tested battery would be 184 km. These variations have to be verified experimentally through a power HiL test.

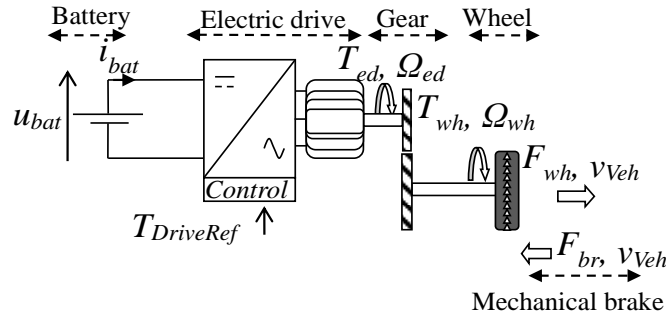

Fig. 3 Structural scheme of the studied EV

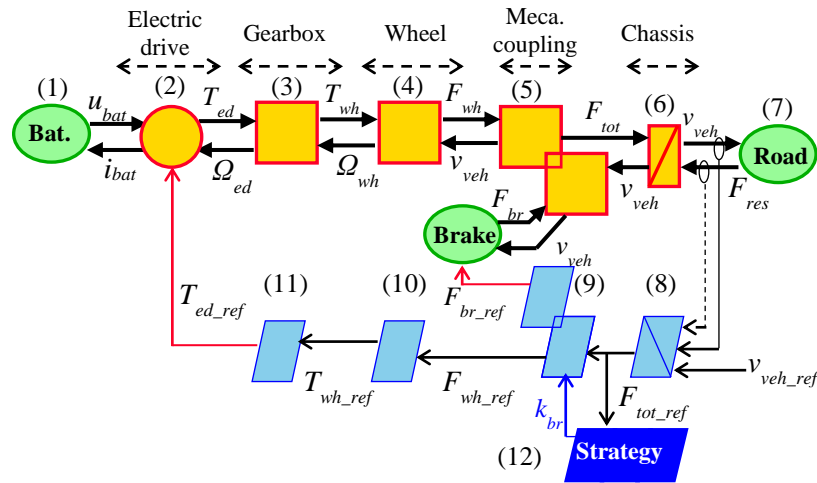

Fig. 4 EMR of the studied EV

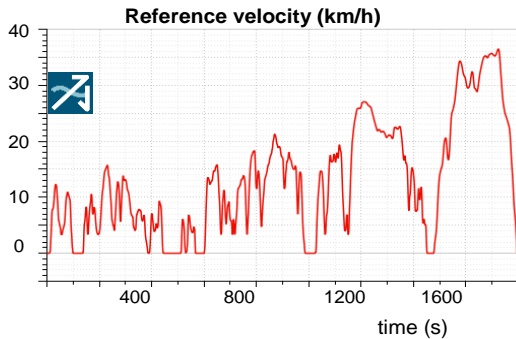

Fig. 5 WLTC reference velocity cycle

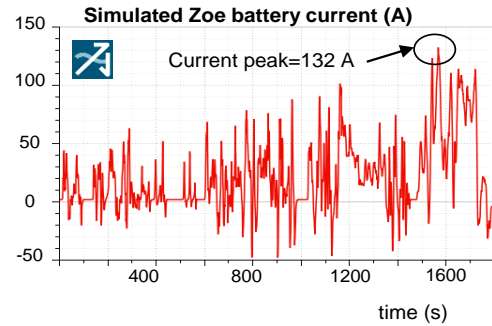

Fig. 6 Simulated battery current for the studied EV

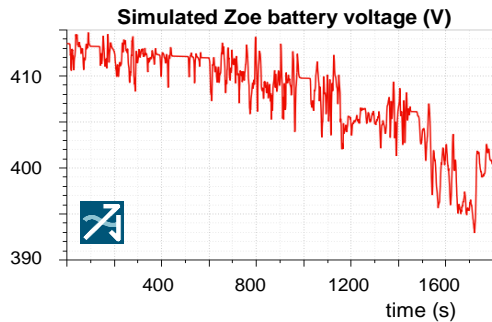

Fig. 7 Simulated battery voltage for the studied EV

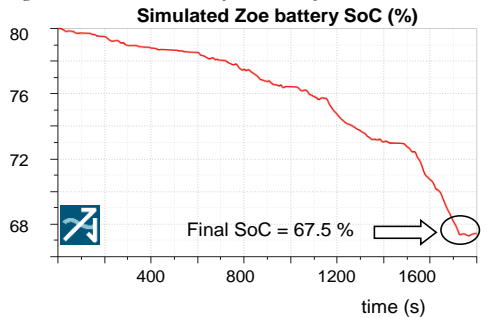

Fig. 8 Simulated evolution of the studied EV SoC

### III. HARDWARE IN THE LOOP TEST

#### A. HiL test bench

From the battery point of view, the traction system is an equivalent source of current. Thus, the hardware components for the test are the battery and a controllable current source (Fig. 9).

The software part is composed of the traction model and control presented in Fig. 4. The battery model has been replaced by the measures from the real one. The output of the traction model controls the current source connected to the battery (Fig. 9). A real-time simulation is compulsory for HiL testing.

In this paper, a single module from the pack is tested. As a consequence, a power adaptation should be used. The adaptation factors are deduced from the architecture of the battery presented in Fig. 2.

$$\begin{cases} u_{ModMes} \cdot 7 = u_{BatEst} \\ i_{ModRef} = i_{BatRef} \end{cases} \quad (13)$$

Fig. 10 presents the HiL test bench developed for the PANDA project[12]. The tested module is placed in the bench in ambient air. No active cooling system is added. The vehicle model is downloaded from the Simcenter Amesim cloud. Then, it is converted to be used in the real-time simulator (Typhoon HIL). The controllable current source is able to deliver +/-200 A and is driven by an analog input. This bench is flexible and the tested vehicle can be easily replaced by other vehicle models downloaded from the Simcenter Amesim Cloud.

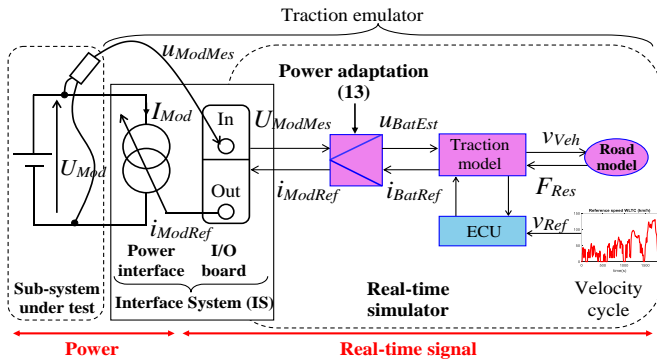

Fig. 9 HiL principle for battery modules testing

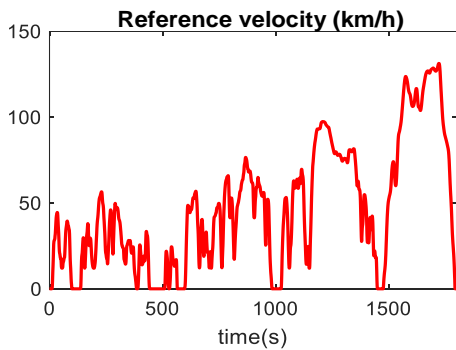

Fig. 11 WLTC reference velocity cycle

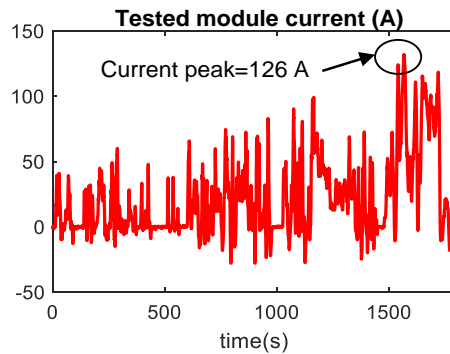

Fig. 12 Experimental module current

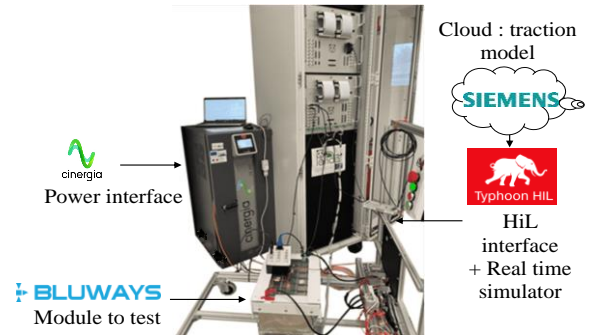

Fig. 10 Developed test bench

#### B. HiL Test of a module

The same velocity cycle is used than for simulation (Fig. 11). The evolution of the current is the same than for simulation (Fig. 12) with small differences due to sensors and modeling assumptions. This is confirmed by the energy consumption with only 1% difference in term of SoC variation between the simulation (cf. Fig. 8) and the experimental results (Fig. 14). The voltage is divided by a factor 7 (Fig. 13) compared to the battery simulation because one module is tested instead of seven in series (section III.A). From an electrical point of view the tested device is perfectly adapted to be used as a battery for the studied EV.

The experimental driving range deduced from the HiL test is 183 km for a WLTC.

Moreover, supplementary information can be obtained during an HiL test. For example, the temperatures of different points on the tested module have been recorded (Fig. 15) such as the ambient air one (Fig. 16). The module self-heating is negligible ( $< 3^{\circ}\text{C}$ ) during a WLTC. The temperature does not exceed  $23^{\circ}\text{C}$  which is optimal for battery operation.

With that full power test, the ability of the tested battery has been validated experimentally from the electrical and the thermal points of view.

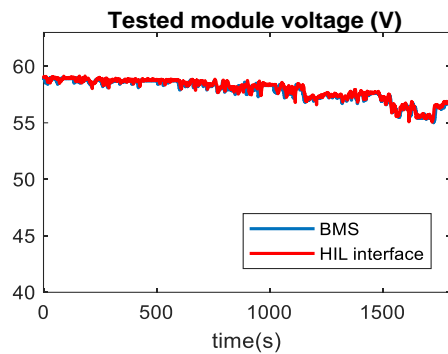

Fig. 13 Experimental module voltage

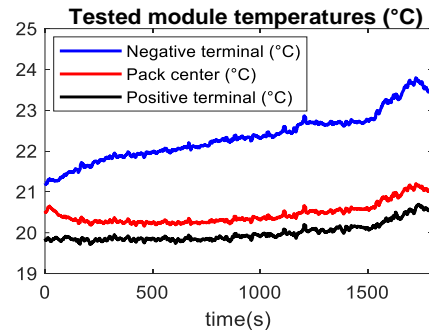

Fig. 15 Experimental temperatures on the tested module

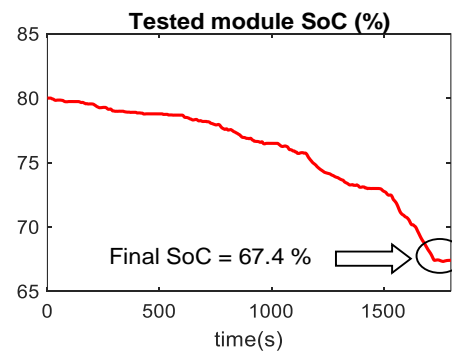

Fig. 14 Experimental module SoC

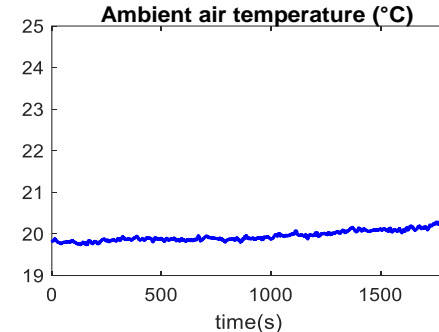

Fig. 16 Experimental ambient air temperature

#### IV. CONCLUSION

In this paper a new battery pack with high power and energy densities has been tested for the Renault Zoe. A Zoe model validated in previous publications has been used [11]. It is organized in EMR. The input is a reference velocity cycle.

The new battery has been first been pre-checked in simulation using a very simple battery model.

Then, a module of this battery has been tested in interaction with the traction model of the studied EV. A specific power test bench based on a controllable current source and real time simulator has been developed.

Appropriate reduction factors ensured the power constraints are the same than a module used in the Renault Zoe.

The HiL power test shows that the tested module stays between its normal operation limits during a WLTC standard velocity cycle. These module results are extendable to the battery if we consider that ambient air circulate between the modules when driving.

The conclusion is that the battery can be used for the studied EV within standard driving conditions.

#### V. ACKNOWLEDGEMENT

This project has received funding from the European Union's Horizon 2020 research and innovation program under grant agreement no. 824256 (PANDA).

#### REFERENCES





- [1] B. Nykvist, and M. Nilsson, "Rapidly falling costs of battery packs for electric vehicles," *Nature Clim Change*, vol. 5, pp. 329–332, 2015.
- [2] W. Cao, J. Zhang, and H. Li, "Batteries with high theoretical energy densities," *Energy Storage Materials*, vol. 26, pp. 46-55, 2020.
- [3] D. W. Gao, C. Mi, and A. Emadi, "Modeling and simulation of electric and hybrid vehicles," *Proceedings of the IEEE*, vol. 95, no. 4, pp. 729–745, 2007.
- [4] J. Jaguemont, L. Boulon, and Y. Dubé, "Characterization and Modeling of a Hybrid-Electric-Vehicle Lithium-Ion Battery Pack at Low Temperatures," *IEEE Transactions on Vehicular Technology*, vol. 65, no. 1, pp. 1-14, 2016.
- [5] R. German, S. Shili, A. Desreueaux, A. Sari, P. Venet, and A. Bouscayrol, "Dynamical Coupling of a Battery Electro-Thermal Model and the Traction Model of an EV for Driving Range Simulation," *IEEE Transactions on Vehicular Technology*, vol. 69, no. 1, pp. 328-337, 2020.
- [6] A. Bouscayrol, "Hardware-In-the-Loop simulation," in *Industrial Electronics Handbook*, Eds. Chicago: CRC Press, Taylor & Francis group, pp. 33-1-33-15, 2011.
- [7] A. Bouscayrol, J. P. Hautier, and B. Lemaire-Semail, "Graphic Formalisms for the Control of Multi-Physical Energetic Systems," in *Systemic Design Methodologies for Electrical Energy tome 1 Analysis Synthesis and Management*, ISTE Willey editions, 2012.
- [8] M. Corno, N. Bhatt, S. M. Savaresi, and M. Verhaegen, "Electrochemical Model-Based State of Charge Estimation for Li-Ion Cells," *IEEE Transactions on Control Systems Technology*, vol. 23, no. 1, pp. 117-127, 2015.
- [9] Kokam, "Superior Li ion battery cells brochure," [https://kokam.com/data/filebox/cell\\_brochure.pdf](https://kokam.com/data/filebox/cell_brochure.pdf)
- [10] A. Desreueaux, A. Bouscayrol, R. Trigui, E. Castex, and J. Klein "Impact of the Velocity Profile on the Energy Consumption of Electric Vehicle," *IEEE Transactions on Vehicular Technology*, vol. 68, n° 12, pp. 11420-11426, 2019.
- [11] C. Husar, M. Grovu, C. Irimia, A. Desreueaux, A. Bouscayrol, M. Ponchant, and P. Magnin, "Comparison of Energetic Macroscopic

Representation and structural representation on EV simulation under Simcenter Amesim,” In Proc. IEEE VPPC '19, Hanoi (Vietnam), 2019.

for models of electrified vehicles and their components,” in Proc. Transport Research Arena '20, Helsinki (Finland), 2020.

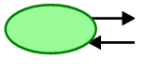
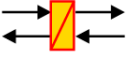
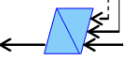
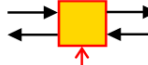
[12] A. Bouscayrol, A. Lepoutre, C. Irimia, C. Husar, J. Jaguemont, A. Lièvre, C. Martis, D. Zuber, V. Blandow, F. Gao, W. Van Dorp, G. Sirbu, and J. Lecoutere, “Power Advanced N-level Digital Architecture

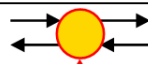
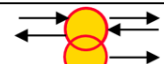
Appendix A: EMR pictograms

	Source element (energy source)		Accumulation element (energy storage)		Indirect inversion (closed-loop control)
	Mono-physical conversion element		Mono-physical coupling element (energy distribution)		Direct inversion (open-loop control)
	Multi-physical conversion element		Multi-physical coupling element (energy distribution)		Coupling inversion (energy criteria)