



HAL
open science

Multi-level simulation of a BEV using EMR methodology

Calin Husar, Eduard Edis Raclaru, Cristi Irimia, Mihail Grovu, Matthieu Ponchant, Joris Jaguemont, Alain Bouscayrol, Ronan German, Mircea Ruba, Claudia Martis, et al.

► **To cite this version:**

Calin Husar, Eduard Edis Raclaru, Cristi Irimia, Mihail Grovu, Matthieu Ponchant, et al.. Multi-level simulation of a BEV using EMR methodology. 2020 IEEE Vehicle Power and Propulsion Conference (VPPC), Nov 2020, Online, Spain. 10.1109/vppc49601.2020.9330943 . hal-03715278

HAL Id: hal-03715278

<https://hal.univ-lille.fr/hal-03715278v1>

Submitted on 6 Jul 2022

HAL is a multi-disciplinary open access archive for the deposit and dissemination of scientific research documents, whether they are published or not. The documents may come from teaching and research institutions in France or abroad, or from public or private research centers.

L'archive ouverte pluridisciplinaire **HAL**, est destinée au dépôt et à la diffusion de documents scientifiques de niveau recherche, publiés ou non, émanant des établissements d'enseignement et de recherche français ou étrangers, des laboratoires publics ou privés.

Multi-level simulation of a BEV using EMR methodology

Călin HUSAR^{1*}, Eduard Edis RACLARU^{1*}, Cristi IRIMIA^{1*}, Mihail GROVU^{1*}, Matthieu PONCHANT^{2*},

Joris JAGUEMONT^{3*}, Alain BOUSCAYROL^{4*}, Ronan GERMAN^{4*}, Mircea RUBA^{5*}, Claudia MARTIS^{5*},

Gabriel Mihai SIRBU^{6*}

¹ Siemens Industry Software SRL, Brasov, Romania

² Siemens Industry Software SAS, Lyon, France

³ Vrije Universiteit Brussel, Belgium

⁴ Univ. Lille, Arts et Metiers Paris Tech, Centrale Lille, HEI, EA 2697- L2EP, F-59000 Lille, France

⁵ Technical University of Cluj Napoca, Romania

⁶ Renault Technologie Roumanie SRL, Bucharest, Romania

* PANDA, Grant Agreement 824256, <https://project-panda.eu>

Corresponding author: Calin.Husar@siemens.com

Abstract— The automotive industry is shifting to mass production of electrified vehicles. Simulation is a key step for developing these new vehicles. System simulation tools as Simcenter Amesim includes ready-to-use multi-physics libraries in that perspective. A new library is being created based on the Energetic Macroscopic Representation formalism to speed-up the battery electric vehicles (BEV) development process. The paper presents the BEV multi-level simulation where the simulations were done using 3 different levels for the battery models. By using “plug & play” method different BEV model configurations can be built in a fast, precise and systematic way.

Keywords— electric vehicles, Energetic Macroscopic Representation, 1D simulation, multi-level simulation, multi-domain, Simcenter Amesim

I. INTRODUCTION

New Battery Electric Vehicles (BEVs) have to be developed quickly to face environmental challenge [1], [2], [3]. Simulation tools are thus a key issue to speed-up this development [4][5][6]. To reduce the simulation development time, prebuilt models are used in various vehicle simulations. They allow to focus on doing simulations of different scenarios and perform analysis on the results, rather than spending time developing new models for each vehicle module.

A BEV can be considered as 3 mains subsystems in interaction: the battery, the electric drive, the vehicle body (vehicle dynamics). Their models must be interconnected for a complete simulation. Many models with different accuracy levels can be developed where the advantage is that a smart reuse or replacement of the models can be done. They can be combined by using “plug & play” method in a simulation process.

This paper presents the multi-level simulation of a BEV developed with the framework of the PANDA H2020 project [7]. The “plug & play” ability is possible because this project uses a unified formalism called energetic macroscopic representation (EMR) that clearly defines the inputs and the outputs of subsystems. An EMR-based library has been developed in Simcenter Amesim [8] in that perspective.

II. GRAPHICAL FORMALISM AND SOFTWARE

A. Energetic Macroscopic Representation

EMR is a graphical description [9], which highlights the energy properties of a system. It organizes the system into interconnected basic elements (Fig. 1). All elements are connected according to the interaction principle meaning the product of the action and reaction is the exchange power [10][11]. Furthermore, all the components are described respecting the physical integral causality: the output is an integral function of the inputs [12][13].

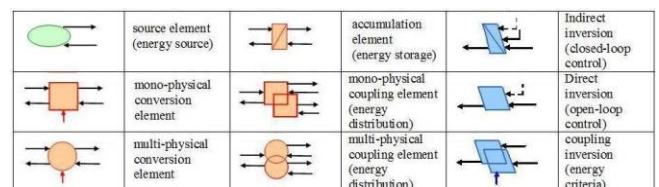

Fig. 1. Pictograms of EMR and its inversion-based control

EMR is a functional description, i.e. it focus of the subsystem function instead of the subsystem physical structure [9][11]. In that aim, only power variables (for example voltage and current in the electrical domain) are exchanged between elements. These variables are organized according to the causality and interaction principles. This feature makes EMR appropriate for multi-physical modelling

as the power can be found in any physical domain (electricity, mechanics ...).

An EMR library has been developed within the Simcenter Amesim software [8]. Each EMR or control element is an empty subsystem containing only the input and output ports. Its internal structure is defined by the user, depending on what it should represent. The existing Signal and Control library from Simcenter Amesim software is used to create EMR simulation models.

B. Simcenter Amesim

To face growing competitive pressures of the development of the electrical vehicles, dedicated software as Simcenter Amesim are used [8][14]. The current study is performed by using the modeling and simulation capabilities of Simcenter Amesim software, as an integrated, scalable system simulation platform.

The predefined models of the studied BEV will be integrated in Simcenter Amesim. The EMR library is used to organize the 3 subsystems. The Signal and Control library is used to develop the models within the EMR elements.

C. EMR simulation development process

To facilitate the realization of simulations of electrified vehicles a set of battery and e-drive models are developed. The development process for EMR simulations into Simcenter Amesim software considers the following steps.

Step 1.

Definition of the different subsystems to be considered (see example in Fig. 2).

Step 2.

Definition of the equivalent EMR elements (Fig. 3).

Step 3.

Interconnection of the EMR elements (Fig. 4) while resolving the conflict of association [9].

Step 4.

Integration of the model equation in the EMR element (Fig. 5) using the Signal and Control library.

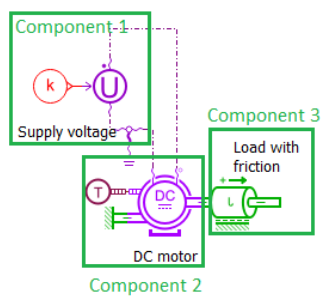

Fig. 2: System level choice

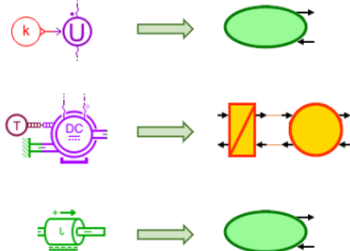

Fig. 3: Component models vs. EMR elements

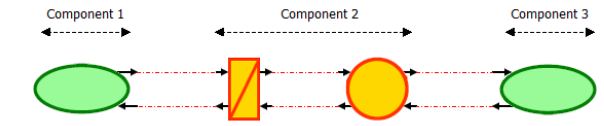

Fig. 4: EMR diagram

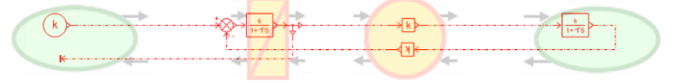

Fig. 5: Equation model

III. VEHICLE COMPONENTS DESCRIPTION

The set of battery, e-drive and body predefined vehicle components offers different complexity levels models. For the same subsystem, different levels of models (from high fidelity models to low-accuracy models) can be used with respect to the defined I/Os. This will enable an easy replacement of a subsystem model by a high-fidelity one without changing the other models of the complete system.

A. Battery models

Different battery models [15][16] have been developed within the framework of the PANDA project [17].

- level 1, ideal constant voltage source;

- level 2, simple equivalent circuit model (Fig. 6), consists of a voltage source (i.e. open-circuit voltage, OCV), dependent on the state of charge, and a resistance; this model would only represent the basic behaviour of the battery, with few functional parameters and no coupling to other advanced features;

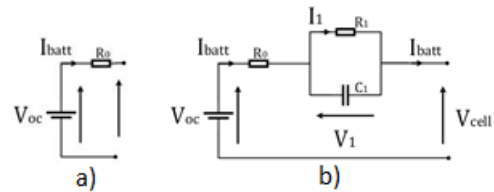

Fig. 6: Representation of the 1st-order Thevenin model a) level 2, b) level 3

- level 3, advanced equivalent circuit model (Fig. 6) with thermal modelling where the aim of the model is to reproduce the cell's electrical and thermal performances with two parts: the electrical and thermal parts (Fig.7). Also, a dynamical behaviour is included due convection and diffusion phenomena.

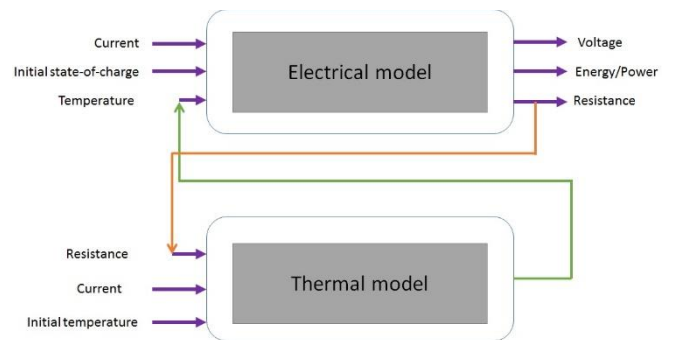

Fig. 7: Schematic of the modelling methodology

B. E-drive model

In this paper, only a unique model for the e-drive is considered [18][19]. To reproduce the vehicle mechanical characteristics a DC machine model with the following characteristics was used:

- nominal useful power : 65 kW ;
- nominal voltage : 400 V ;
- nominal current : 162 A ;
- nominal speed : 2840 rpm ;
- armature resistance : 350 mΩ ;
- armature inductance : 6.5 mH..

C. Body model

Only a unique body model is considered. It consist in a simple longitudinal vehicle dynamics with resistive forces, which contain: a gear ratio, a differential, two wheels, the vehicle mass and resistive force.

IV. VEHICLE MODEL INTEGRATION

A. Multi-level simulation structure

The structure of prebuilt vehicle component models is implemented in Simcenter Amesim in the form of a folder tree structured as shown in Fig. 8.

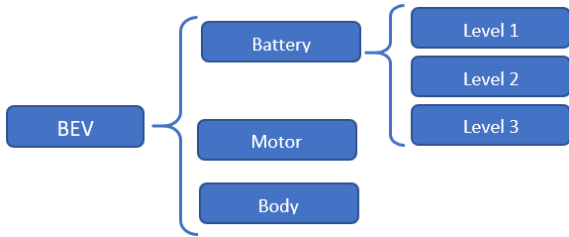

Fig. 8 Prebuilt component models for BEV

Having different n-level models of the same system, in the same simulation package, one subsystem can be replaced by another. Thus, different models of the same component, depending on the level of simulation that wants to be tackle, can be used (multi-level models). A modularization of the BEV simulation is thus developed.

B. Multi-level simulation process

The simulation of the full vehicle is done by coupling the existing vehicle subsystems. A wide variety of influential boundary conditions and factors are analyzed and taken into account during the simulation.

Based on the EMR organization and analysis, I/Os of subsystems are strictly defined (Fig. 9). In order to avoid conflict of association any model should be developed with the respect of these defined I/Os.



Fig. 9. BEV topology and components interconnections variables

For each individual subsystem, based on its EMR, the local control is derived following the inversion-based control rules. The global local control of the entire BEV is thus systematically deduced from the EMR by mirror effect (Fig. 10).

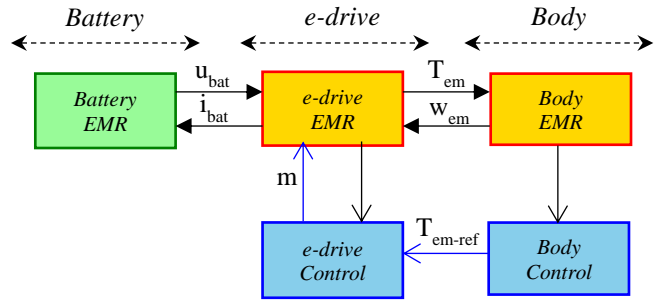

Fig. 10. BEV organization.

The e-drive and vehicle body EMR-based models come with prebuilt inversion-based controls included.

1. The e-drive has a prebuilt torque control with current regulation.
2. The body has a prebuilt vehicle velocity control.

For flexibility of the reuse of developed models a pre-study is required for:

1. Selecting the right level of the model;
2. Solving the conflict of association;
3. Proposing the right model.

C. EMR Vehicle Methodology Integration

Prebuild models have thus been developed in Simcenter Amesim (Fig. 11, Fig. 12, Fig. 13). They can be interconnected to achieve the global simulation.

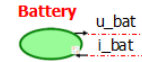

Fig.11: Pre-defined battery model

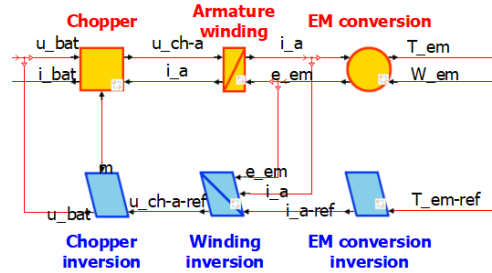

Fig. 12: Pre-defined e-drive model and control

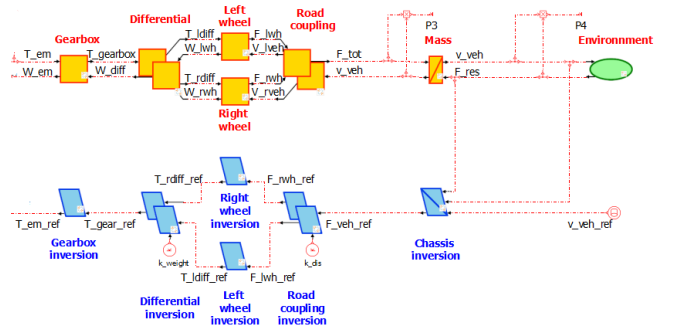

Fig. 13: Pre-defined vehicle body model and control

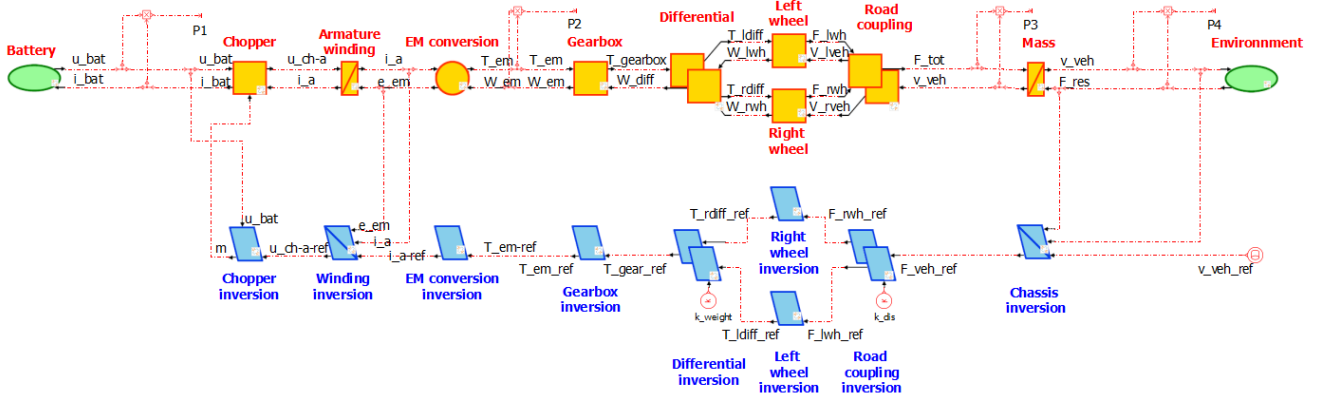

Fig. 14: Complete BEV EMR model

With the EMR of the vehicle model constructed, the global control structure needs to be determined.

The vehicle control structure is built by “inverting” the EMR elements using the inversion-control rules. This can be achieved by using the predefined controllers for the e-drive and the body. By connecting T_{em_ref} , from the controller for vehicle body, to T_{em_ref} , from the controller for drive the global control structure is created.

The complete EMR structure of the BEV indicates the physical interaction variables between all the BEV subsystems (Fig. 14).

V. SIMULATION RESULTS

The simulation of the complete vehicle is achieved for the urban part of the NEDC cycle (Fig. 15).

Using the EMR organization, based on the different complexity models, can be elaborated different scenarios of electric vehicle operations using different control strategies.

A. Setup parameters

Table. 1: Vehicle parameters.

Name	Value	Unit
Nominal speed	2840	rpm
Nominal battery voltage	400	V
Nominal battery current	162	A
Gearbox ratio	5	-
Equivalent mass	1600	kg
Wheel diameter	0.52	m
Static friction force	50	N
Drag coefficient	0.35	-
Density of the air	1.233	kg/m ³
Vehicle frontal area	2	m ²

B. Validation of control design

The simulation of the BEV using the three levels of complexity for the battery models is firstly used to validate the control design,

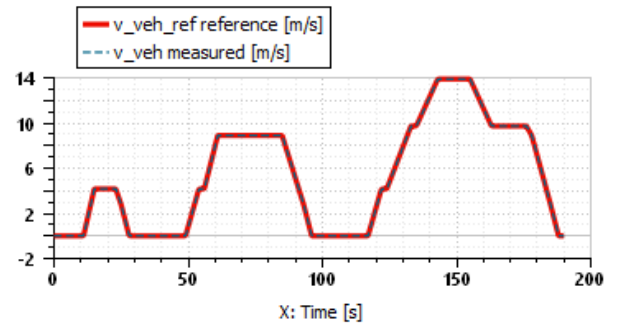

Fig. 15: Vehicle velocity tracking for battery level 1.

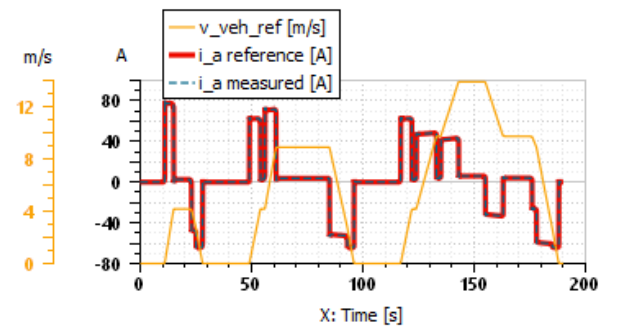

Fig. 16: Armature current for battery level 1.

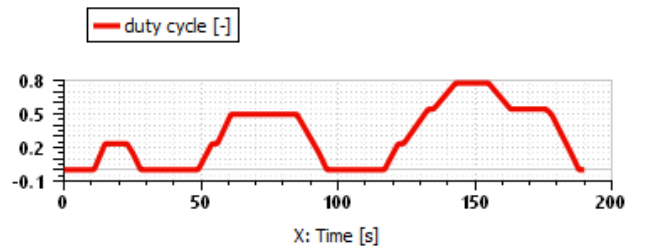

Fig. 17: Chopper modulation ratio for battery level 1.

In Fig. 16, a comparison of velocity profile with the current profile shows the regenerative braking function of the e-drive. The duty cycle is plotted in Fig. 17.

Similar results are obtained for level 2 and level 3 battery models.

C. Battery variables

The voltage and current through the battery for the three levels of battery models are compared in Fig. 18.

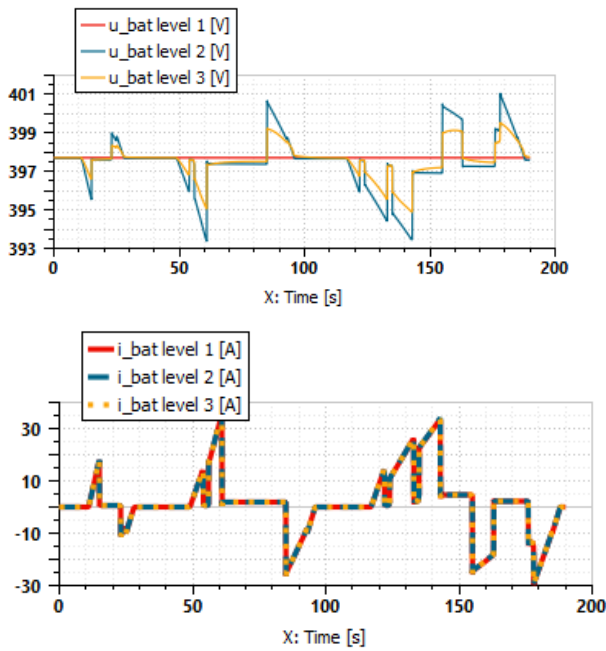

Fig. 18: Battery voltage and current for the three level models.

Level 2 and 3 models have the voltage which reacts to the current variation and the state-of-charge. Level 3 model adds the dynamic model to the battery which is visible in the voltage characteristics.

Level 2 and 3 models offer an evaluation of the state-of-charge (Fig. 20). The SOC for level 3 is more accurate as it uses both charge and discharge characteristics of the battery as well as temperature dependence and dynamical behavior.

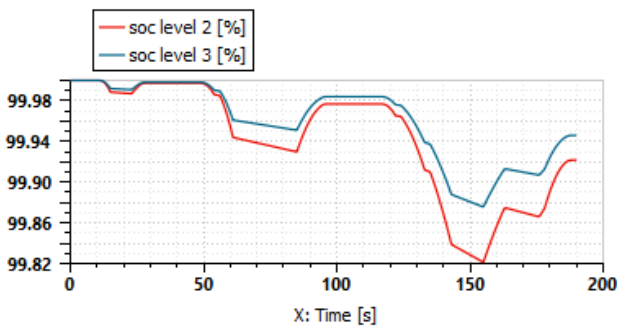

Fig. 19: State of charge.

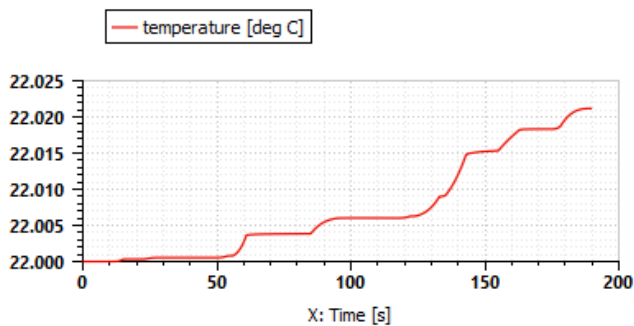

Fig. 20: Temperature evolution for battery level 3.

The temperature evolution of the battery for the NEDC is shown in Fig. 20. The temperature evaluation is important for designing a thermal management system for the battery.

D. Power balance

Energy losses are indicated from the power balance at different stages of the BEV diagram. The EMR description allows us to easily identify the interfaces where these power evaluations are located. The EMR elements indicate how the power undergoes different transformations along EV power structure.

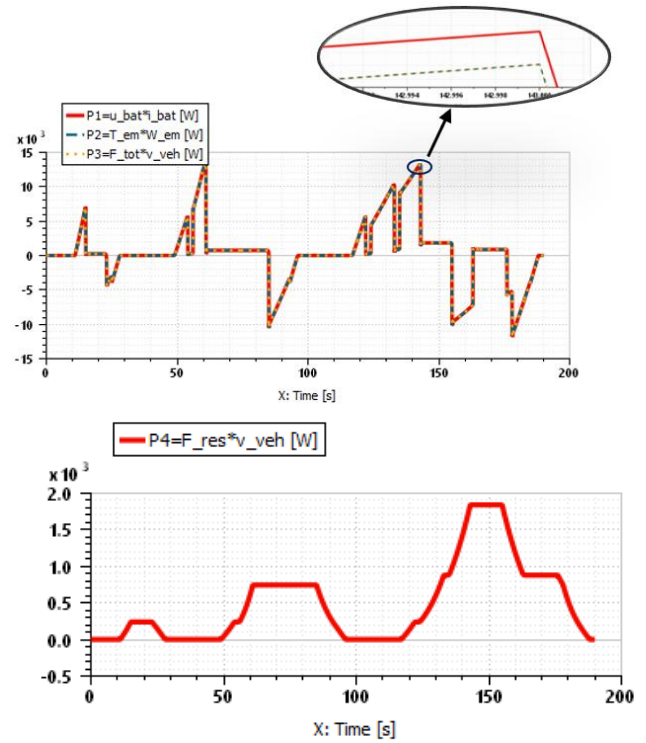

Fig. 21: Power balance for level 1 battery.

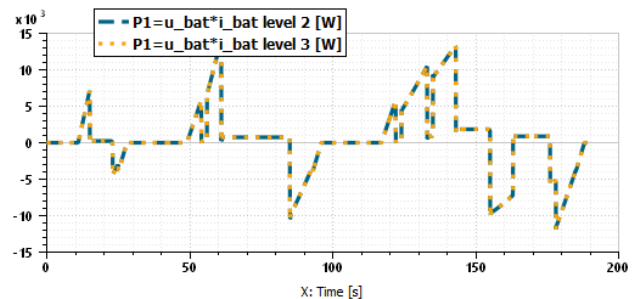

Fig. 22: Battery instantaneous power for different level models.

Even with different complexity battery models, the simulation results indicate similar power losses (for level 2 and level 3) along the EV power structure (Fig. 22).

The level 1 of battery can be used just for simple EV simulation, such as for controller performance, as the computations are faster. The level 2 battery is used when the battery model present interest to be personalizing to a certain technology by providing data on the characteristic of the open-circuit-voltage based on the state-of-charge. This model is used also to evaluate the battery state-of-charge. The level 3 of battery, is used to obtain the same results as

in level 2 but with an increased accuracy. This level is used to model the dynamical behavior of the model due to diffusion and convection phenomena. With the level 3 model, the thermal behavior of the battery can be predicted and its effect on the battery electric variables.

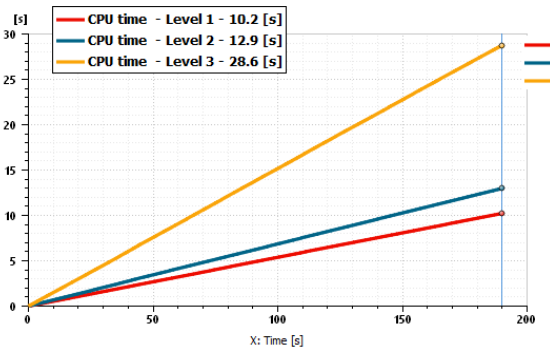

Fig. 23: CPU of the simulation of the 3 model levels

The CPU time is plotted for all model levels for the same simulation time (Fig. 23). Of course the model level 3 has the highest computation time: this more accurate model leads to multiply the computation time by 3 in comparison with model level 1.

VI. CONCLUSION

The process of developing an electrified vehicle simulation based on the set of predefined vehicle components has been presented. Multi-level models of batteries can be easily integrated in a complete BEV model. Based on the chosen level of complexity different scenarios, useful for EV development, have been tested. Using the presented method, flawless simulations of different connected models have been easily achieved which help reduce the EV development time.

In terms of computation time, the difference between the use of level 1 of battery and level 3, is almost triple in time. If for a short simulation time it can be neglected, for a long speed profile and more complex case, the level of complexity it could be to be considered since the complexity of the model slows down the simulation time. Thus, the users can choose level of models as a function of the accuracy but also as a function of the simulation time.

In future work, multi-level models for the electric motors and vehicle dynamics will be added. Also, the multi-level approach will be expanded to accommodate as well, plug-in hybrid electric vehicles (P-HEV) and fuel-cell electric vehicles (FCEV).

ACKNOWLEDGMENT

The research leading to these results has received funding from the European Community's Horizon 2020 Program under grant agreement No. 824256 (PANDA).

REFERENCES

- [1] "Global EV outlook 2018, towards cross-modal electrification", International Energy Agency report, 2018.
- [2] C. C. Chan, "Overview of electric, hybrid and fuel cell vehicles", in *Encyclopedia of Automotive Engineering*. Hoboken, ch. 5, NJ, USA: Wiley, 2015.
- [3] M. Ehsani, Y. Gao, S. E. Gay, A. Emadi, "Modern Electric, Hybrid Electric, and Fuel Cell Vehicles". Elec. Eng., CRC Press, ISBN 9781138330498, February 2018.
- [4] L. Guzzella and A. Amstutz, "CAE tools for quasistatic modelling and optimization of hybrid powertrains", *IEEE Trans. on Veh. Techn.*, vol. 48, no. 6, pp. 1762–1769, November 1999.
- [5] Z. Rubin, S. Munns, J. Moskowa, "The development of vehicular powertrain system modeling methodologies: philosophy and implementation", *System Automotive Engineering*, paper 971089, 1997.
- [6] D. W. Gao, C. Mi, and A. Emadi, "Modeling and simulation of electric and hybrid vehicles", *Proceeding of the. IEEE*, vol. 95, no. 4, pp. 729–745, April 2007.
- [7] A. Bouscayrol, A. Lepoutre, C. Irimia, C. Husar, J. Jaguemont, A. Lièvre, C. Martis, D. Zuber, V. Blandow, F. Gao, W. Van Dorp, G. Sirbu, J. Lecoutere, "Power Advanced N-level Digital Architecture for models of electrified vehicles and their components", *Transport Research Arena 2020*, Helsinki (Finland), April 2020.
- [8] C. Husar, M. Grovu, C. Irimia, A. Desrevelaux, A. Bouscayrol, M. Ponchant, P. Mangin, "Comparison of Energetic Macroscopic Representation and Structural Representation on EV Simulation under Simcenter Amesim", *IEEE VPPC'19*, Hanoi (Vietnam), October 2019.
- [9] A. Bouscayrol, J. P. Hautier, B. Lemaire-Semail, "Graphic Formalisms for the Control of Multi-Physical Energetic Systems", *Systemic Design Methodologies for Electrical Energy*, tome 1, Analysis, Synthesis and Management, Chapter 3, ISTE Willey editions, October 2012.
- [10] A. Bouscayrol, B. Davat, B. de Fornel, B. François, J. P. Hautier, F. Meibody-Tabar, M. Pietrzak-David, "Multimachine Multiconverter System: application for electromechanical drives", *European Physics Journal - Applied Physics*, vol. 10, no. 2, pp. 131-147, May 2000.
- [11] P.J. Gawthrop, G.P. Bevn G.P., "Bong Graph modeling, a tutorial introduction for control engineers", *IEEE Control Systems magazine* vol. 27, no. 2, pp. 24-45, 2007.
- [12] I. Iwasaki, H.A. Simon, "Causality and model abstraction", *Artificial Intelligence*, vol. 67, pp. 143-194, 1994.
- [13] J.P. Hautier, P.J. Barre, « The causal ordering graph – A tool for modeling and control law synthesis", *Studies in Informatics and Control Journal*, vol. 13, no. 4, pp. 265-283, 2004.
- [14] Simcenter Amesim <https://www.plm.automation.siemens.com/>
- [15] X. Hu, S. Li, and H. Peng, "A comparative study of equivalent circuit models for Li-ion batteries," *Journal of Power Sources*, vol. 108, pp. 359-367, 2012.
- [16] G. L. Plett, *Battery Management Systems, Volume I: Battery Modeling*, Norwood, MA, USA: Artech House, 2015.
- [17] J. Jaguemont, C. Husar, R. German, "Multi-level knowledge models of batteries", PANDA H2020 GA# 824256, D2.1 Deliverable, public report, May 2020, [Online] Available: <https://project-panda.eu/> Accessed May 2020).
- [18] M. Ruba, C. Husar, "Multi-level knowledge models of e-drive", PANDA H2020 GA# 824256, D3.1 Deliverable, public report, November 2019, [Online] Available: <https://project-panda.eu/> Accessed May 2020).
- [19] A. Desrevelaux, M. Ruba, A. Bouscayrol, G. Sirbu, C. Martis, "Comparisons of models of electric drives for electric vehicles", *IEEE-VPPC'19*, Hanoi (Vitenam), October 2019.