

# Low-frequency ultrasound skin mechanical impedance sensor for Pressure Ulcer diagnostic

Elis Marina SALES DE CASTRO \*

Betty LEMAIRE-SEMAIL \*

Frédéric GIRAUD \*

\* Université de Lille,

Univ. Lille, Arts et Metiers Institute of Technology, Centrale Lille, Junia, ULR 2697 - L2EP, F-59000 Lille, France  
*elis-marina.sales-de-castro@univ-lille.fr*

**RESUME** - Les escarres représentent un problème sanitaire majeur non seulement pour les patients, mais aussi pour la santé publique. Ses coûts pour la qualité de vie des patients et pour les finances publiques peuvent être réduits si son diagnostic se fait suffisamment tôt. Des nombreux efforts ont été faits en cherchant une solution pour ce diagnostic, en analysant l'hydratation ou l'impédance électrique de la peau, par exemple. Jusqu'à présent, aucune méthode n'est suffisamment fiable. Dans ce contexte, un dispositif de mesure d'impédance mécanique de la peau, utilisant des ultrasons de "basse fréquence", est proposé, avec le but d'offrir une alternative qui peut-être fiable et non-invasive. Dans ce travail, nous proposons d'utiliser un transducteur de Langevin pour fournir une mesure des caractéristiques mécaniques de la peau. Des premiers résultats obtenus montrent que l'impédance mécanique permet de discriminer la peau selon la localisation de la mesure.

**ABSTRACT** - Pressure ulcers are a concern not only for the patients who suffer from them, but also for public health. Its costs to the quality of life of patients and to the public finances can be reduced with an early diagnostic. Several efforts have been made to find a solution for this diagnostic, for example by analysing the hydration or the electrical impedance of the skin. So far, no method is sufficiently reliable. In this context, a low-frequency ultrasound device is proposed, with the aim of offering an alternative that can be reliable and non-invasive. The Langevin transducer is a highly efficient device that can provide a measurement of the mechanical characteristics of the skin. Initial results show that mechanical impedance can discriminate the skin according to the location of the measurement.

**MOTS-CLES** - Diagnostics, Langevin Transducer, Low frequency ultrasound, Pressure Ulcers, Skin mechanics.

## 1. Introduction

The skin is an organ composed by several layers, with functions such as protection of the body, regulation of its temperature, production of vitamin and sensitive nerve endings [1]. These functions depend on skin integrity, that can be compromised, for instance, by chronic wounds (CW). Hypoxia process, where the blood flow is blocked, and the skin cells start to die, is the main cause of CW. It is due to vascular diseases, poor nutrition, shear and pressure [2], [3]. Depending on the aetiology of the CW, it can be classified as vascular ulcers, diabetic ulcers or pressure ulcers (PU). The latter is quite common for intensive care unit patients, neonates, elderly and patients with spinal cord injury, due to their limited mobility [4].

Pressure ulcers are defined by the European Pressure Ulcer Advisory Panel as damage to the skin (and potentially soft tissues) over a bony prominence, being classified by stages I to IV, where stage IV is the most severe. The patients at risk are those exposed to intense or prolonged pressure, combined with friction and shear [5].

For the patients, PU can affect the quality of life, due to pain, difficulty to sleep or even low self-esteem. For public health, it represents large costs, especially when it achieves stage IV. In France, PU treatment costs were estimated to be around 3.35 billion euros a year, with treatments ranging from €1,575 to €5,858 for patient [6]. Thanks to a campaign named "Sauve ma peau, maîtriser le risque escarre", the region Île-de-France saved over 8 million euros for public health with the prevention and early diagnosis of PU [7].

Treating PU in early stages, while it is simple to control, is a strategy to have a harmless, faster and economical recover. However, the diagnosis can be tricky. So far, the most common method is visual assessment of the region, with the analysis of the colour, temperature, hydration and presence of oedema. To avoid this type of diagnostic, that is inaccurate and depends on subjectivity of the healthcare professionals, other tools were proposed, such as imaging, inflammatory biomarkers or sub-epidermal moisture [5], [8]. However, none of them are reliable enough to assure the presence of an early stage of PU. Understanding the mechanics of skin can lead to an alternative for PU diagnosis.

In the context of skin healthcare, Low-frequency ultrasound (LFU) is applied in two different aims: drug delivery and debridement. After the incidence of LFU on the skin, its permeability may change for a determined duration, due to an effect named sonophoresis. The LFU vibration yields a cavitation in the interstitial fluids of skin. Cavitation bubbles serve as

a carrier for molecules and particles inside the tissue [9], [10], functioning for drug deliver to the body. This mechanism is also used for CW debridement, i.e. the cleansing process of the wound. The presence of biofilms and unhealthy tissue cause infections and delay or impede the healing process of a CW. The removal of these debris by cavitation is less painful and complex than surgical or autolytic/enzymatic mechanisms [11].

Although used in skin healthcare as complementary treatment and drug deliver, there is no indication of LFU in diagnostic of skin wounds. However, in [12] the authors propose a method to measure the acoustic force provided by a finger in contact with a 25kHz vibrating surface. They use the voltage difference between the no-load condition and the contact with skin condition, relating it to the contact forces. The method permits the calculation of the biomechanical properties of a fingertip. As the skin mechanical properties are an important index of clinical diagnosis, the use of this technology can be applied in PU at-risk parts of the skin, for PU identification.

This paper presents a novel device for skin mechanical impedance measurement, for an application in PU diagnosis. It consists of a LFU transducer used as a sensor. The system architecture contains a Langevin transducer (LT), controlled with the vector control method [13], guaranteeing a high efficiency, non-invasive and stable device for skin analysis. Firstly, the device is being used on healthy skin, to verify the consistency of the measurements. The next sections approach the design, identification and control of the system's device, followed by the results and conclusions.

## 2. Low-Frequency Ultrasound sensor based on a Langevin Transducer

The studies of mechanical properties of skin are commonly taken by stretching skin and analysing its deformations [14]. Here, the interest is to use ultrasound vibrations, which do not apply any macroscopic or painful stretch to the skin, and study the response of the skin to them. The device developed for the LFU generation is composed by an LT and its generation circuit, the holding structure, a microcontroller and a host computer running MATLAB, as depicted in Figure 1.

The LT uses the inverse piezoelectric effect, creating mechanical deformations by the application of an electrical signal, provided by the generation circuit. The input voltage is controlled in such a way that the vibration remains the same in no-load operation and loaded operation, the latter being when the LT is in contact with the skin. The holding structure is a reliable way to control the indentation force of the LT over the skin.

When operating close to the resonance frequency, LT can be represented as a mass-spring-damper (MDK) system, whose instantaneous vibration  $w$  is described by the mathematical equation presented in (1). In the equation,  $M$ ,  $D$  and  $K$  are the acoustical mass, damper and spring coefficients;  $v$  is the input voltage and  $N$  is the transformer ratio, defining the relation between the current and the velocity  $\dot{w}$  of the vibration. In the LT mass-spring-damper system from (1),  $f_r$  represents the external force applied on the LT by the skin [15]. When the device vibrates at no-load condition,  $f_r = 0$ .

$$M\ddot{w} + D\dot{w} + Kw = Nv - f_r \quad (1)$$

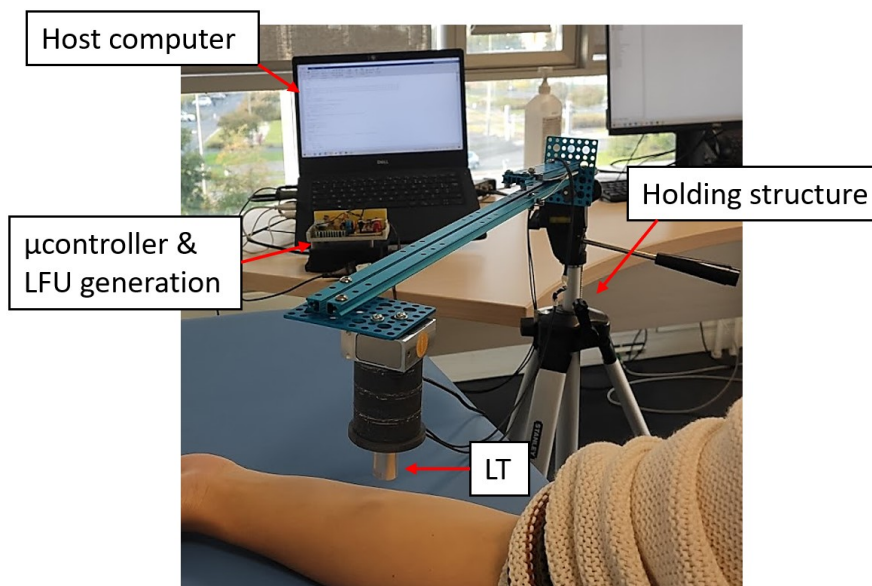

Figure 1: Set-up of the LFU diagnostic sensor

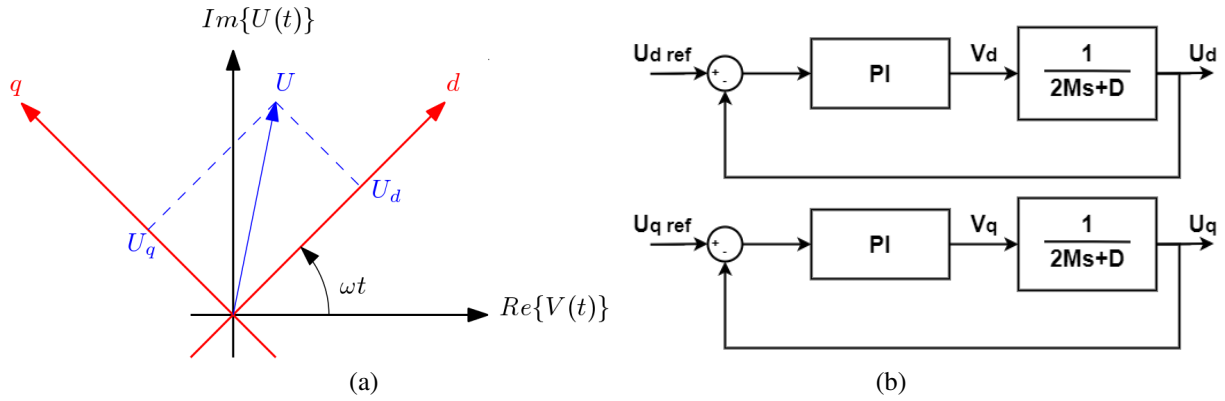

Figure 2: (a) Rotating reference frame de2021vector (b) Design for the plant and controller

## 2.1 Identification of the model

Before designing the system control, it is essential to identify the parameters of the device's MDK model. As the vector control approach was applied, this system is described in the  $[d, q]$  rotating reference frame [15], [16]. Due to the behaviour of the vibration, the variable to control chosen was the velocity. Equations (2,3) present the transfer function of the  $[d, q]$  system in function of the velocity  $u(t) = w(t)$ .

$$2M\dot{U}_d + DU_d + (K - M\omega^2)U_q = NV_d - F_{rq} \quad (2)$$

$$2M\dot{U}_q + DU_q - (K - M\omega^2)U_d = NV_q - F_{rq} \quad (3)$$

To identify the parameters of the model, the transducer vibrates in a no-load ( $f_r = 0$ ) condition, around its resonance frequency. The nominal resonance is 60 kHz, so a vibration test is taken, with an input of  $V_d = 10V$  and  $V_q = 0$ , with the frequency sweeping from 60800 Hz to 61200 Hz. Using the model presented in [13], and considering  $V = V_d$ , since no  $V_q = 0$ , the equation of the velocity circle, is described by 4:

$$U_q^2 + \left(U_d - \frac{NV}{2D}\right)^2 = \left(\frac{NV}{2D}\right)^2 \quad (4)$$

The values found for the MDK system is  $M = 3.1$  g,  $D = 3.1390$  Ns/m,  $K = 460.49$  N/ $\mu$ m and  $N = 0.55$  N/V, after the analysis of the vibration behaviour of the device, for the same voltage input and different frequencies.

## 2.2 System control

After the model of the vibrator is defined and identified, it is possible to design the controller of the system. The vector control, method chosen for the device, suggests that one controller is designed for each axis, once the system is represented in the rotating reference frame. For this project, one PI controller was designed for the direct velocity  $U_d$  and replicated in the quadrature  $U_q$ . It may be noted that a simple PI controller is enough because working in a rotating reference frame (Figure 2) the issue of high frequency of the signals is solved.

The requirements of the controller were a response time  $\tau = 3$  ms, at the resonance frequency (where the model from (1) is valid). To assure the system operates in the resonance frequency, a sweep, such as described in 2.1, is made with  $V_q = 0$ . At resonance,  $\omega_0 = \sqrt{K/M}$ , then (2,3) when  $U_q = 0$ .

The PI parameters are calculated considering the dominant pole compensation [16]. Equation 5 presents the relationship of the PI parameters after the compensation:

$$\frac{K_P}{K_I} = \frac{2M}{D} \quad (5)$$

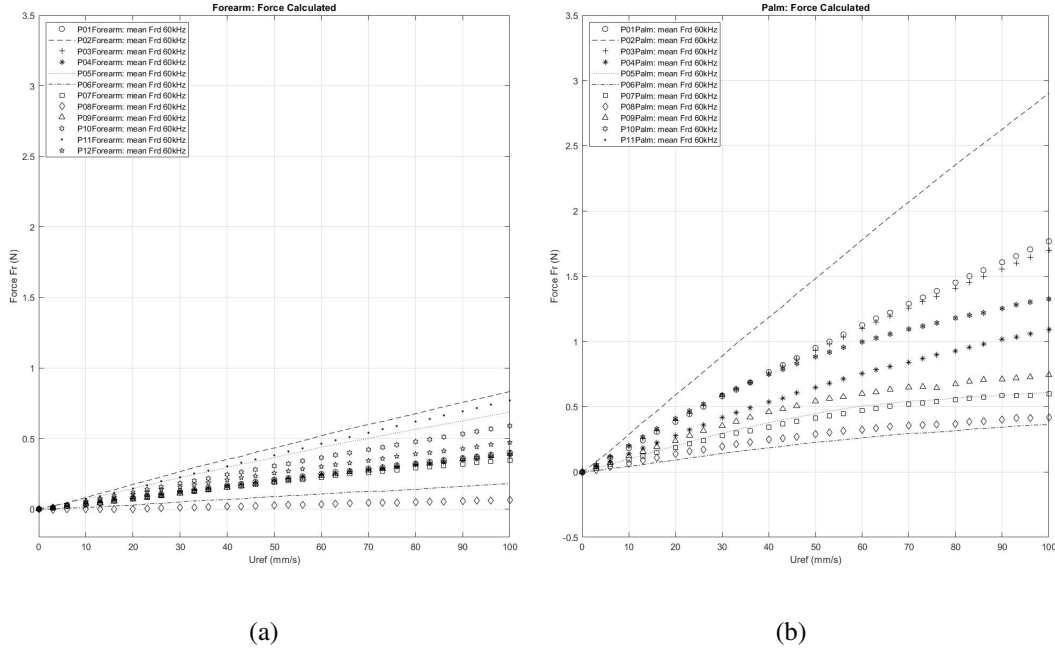

Figure 3: Results of acoustic force in the (a) forearm and (b) palm of the hand for 12 participants

As  $\tau = 3\text{ms}$ , then:

$$\frac{3D}{K_I} = 0.003 \quad (6)$$

and

$$K_P = 3 \frac{2M}{0.003} \quad (7)$$

As the controller assures the behaviour of the vibration for a velocity reference, the calculation method uses a no-load test taken right after contacting the skin with the device. After the implementation of the controller, the left side of (1) is the same for in-contact and no-load operation [16], so it is possible to extract  $f_r$  using the measured values of  $v$ , as given in (8):

$$f_r = N(v_{in-contact} - v_{no-load}) \quad (8)$$

Using this calculation method, tests were taken *in-vivo*, as presented in the next section.

### 3. Results on human skin

In order to build a data set of skin parameters, the tests taken so far used a healthy population with no risk of PU. All the experiments were approved by the ethics and data protection committee of the University of Lille. The group of participants consisted of 12 healthy persons (3 female, 9 male) with age ranging from 22 to 37 years old, all with a normal body mass index. Two body parts were tested: the palm of the hand and the forearm.

The vibration applied was a velocity staircase from 0 to 100 mm/s, that was executed 10 times in each way (ascending and descending) with a resonance frequency of about 60 kHz. The normal force imposed for the contact was 0.2 N, supervised by a normal force sensor attached to the LT.

The values of  $f_r$  are only studied in the direct axis, because the reference velocity  $Uq$  is zero. Thus, in the results of the Figure 3,  $f_r = Frd$ . For one curve, each point represents the mean of 20 points (10 for ascending and 10 for descending) of vibration from 0 to 100 mm/s. Each curve depicts the acoustical force of one participant.

The palm of the hand is a glabrous skin, containing different tissue characteristics, when compared to the forearm. For example, the non-glabrous skin has hair follicles and its epidermal thickness is about half of the glabrous skin [17]. From Figure 3, a different response from the palm and the forearm are quite noticeable, indicating that the LFU device can show the variation in skin mechanics. Moreover, we notice that the apparent stiffness of the palm is higher than the forearm's, results consistent with [14]

## 4. Conclusion

The LFU diagnostic tool based on an LT was used in [16] to identify phantom skin with different hardnesses. Here, the mechanical impedance of healthy skin was studied with the analysis of the acoustical force, in two different body parts. Both parts of skin analysed are very different from each other: the palm of the hand has glabrous skin, while the forearm has a non-glabrous one. Thanks to its different responses in each part of the arm tested, it was possible to distinguish them by comparing the curves. In most of the cases, the palm shows higher force values, which indicates a higher mechanical impedance.

As a result of PU, changes in skin mechanical impedance are expected [14]. Thus, for future applications, a follow-up of the skin in the same spot can be done, in order to analyse the changes of skin in the same day. Once this type of study is established, the LFU diagnosis tool could be used in PU at-risk patients as a powerful device for PU detection.

## Acknowledgements

This research was undertaken within the “Skin Tissue Integrity under Shear” (STINTS) project that has received funding from the European Union’s Horizon 2020 research and innovation programme under the Marie Skłodowska-Curie Grant Agreement No. 811965.

This work has been carried out within the framework of IRCICA (CNRS Service and Research Unit 3380) in Lille, France.

## References

- [1] A. K. Dkabrowska, C. Adlhart, F. Spano, G.-M. Rotaru, S. Derler, L. Zhai, N. D. Spencer, and R. M. Rossi, “In vivo confirmation of hydration-induced changes in human-skin thickness, roughness and interaction with the environment,” *Biointerphases*, vol. 11, no. 3, p. 031 015, 2016.
- [2] A. Gefen, “How do microclimate factors affect the risk for superficial pressure ulcers: A mathematical modeling study,” *Journal of tissue viability*, vol. 20, no. 3, pp. 81–88, 2011.
- [3] J. White, N. Ivins, A. Wilkes, G. Carolan-Rees, and K. G. Harding, “Non-contact low-frequency ultrasound therapy compared with uk standard of care for venous leg ulcers: A single-centre, assessor-blinded, randomised controlled trial,” *International Wound Journal*, vol. 13, no. 5, pp. 833–842, 2016.
- [4] J. S. Mervis and T. J. Phillips, “Pressure ulcers: Pathophysiology, epidemiology, risk factors, and presentation,” *Journal of the American Academy of Dermatology*, vol. 81, no. 4, pp. 881–890, 2019.
- [5] A. Gefen, P. Alves, G. Ciprandi, F. Coyer, C. T. Milne, K. Ousey, N. Ohura, N. Waters, and P. Worsley, “Device-related pressure ulcers: Secure prevention,” *Journal of wound care*, vol. 29, no. Sup2a, S1–S52, 2020.
- [6] N. Derrien, *Nutrition et cicatrisation : Réduire les coûts liés à l’escarre*, <https://www.agevillagepro.com/article-6182-1-Nutrition-et-cicatrisation-reduire-les-couts-lies-a-l-escarre.html>, (accessed: 31.08.2020), 2019.
- [7] Hospitalia, *Campagne sauve ma peau : Plus de 16 000 patients n’ont pas développé d’escarre en île-de-france, 8 millions d’euros économisés*, <https://www.hospitalia.fr/Campagne-Sauve-ma-peau-plus-de-16-000-patients-n-ont-pas-developpe-d-escarre-en-Ile-de-France-8-millions-d-eurosa291.html>, (accessed: 07.09.2020), 2014.
- [8] Z. Moore, D. Patton, S. L. Rhodes, and T. O’Connor, “Subepidermal moisture (sem) and bioimpedance: A literature review of a novel method for early detection of pressure-induced tissue damage (pressure ulcers),” *International Wound Journal*, vol. 14, no. 2, pp. 331–337, 2017.
- [9] S. Mitragotri and J. Kost, “Low-frequency sonophoresis: A review,” *Advanced drug delivery reviews*, vol. 56, no. 5, pp. 589–601, 2004.
- [10] S. Rashidi, “A review of mechanism of actions of ultrasound waves for treatment of soft tissue injuries,” *International Journal of Green Pharmacy (IJGP)*, vol. 11, no. 01, 2017.
- [11] Y.-J. R. Chang, J. Perry, and K. Cross, “Low-frequency ultrasound debridement in chronic wound healing: A systematic review of current evidence,” *Plastic Surgery*, vol. 25, no. 1, pp. 21–26, 2017.
- [12] A. Kaci, A. Torres, F. Giraud, C. Giraud-Audine, M. Amberg, and B. Lemaire-Semail, “Fundamental acoustical finger force calculation for out-of-plane ultrasonic vibration and its correlation with friction reduction,” in *2019 IEEE World Haptics Conference (WHC)*, IEEE, 2019, pp. 413–418.
- [13] F. Giraud and C. Giraud-Audine, *Piezoelectric Actuators: Vector Control Method: Basic, Modeling and Mechatronic Design of Ultrasonic Devices*. Butterworth-Heinemann, 2019.
- [14] Q. Wang, L. Kong, S. Sprigle, and V. Hayward, “Portable gage for pressure ulcer detection,” in *2006 International Conference of the IEEE Engineering in Medicine and Biology Society*, IEEE, 2006, pp. 5997–6000.
- [15] S. Ghenna, F. Giraud, C. Giraud-Audine, and M. Amberg, “Vector control of piezoelectric transducers and ultrasonic actuators,” *IEEE Transactions on Industrial Electronics*, vol. 65, no. 6, pp. 4880–4888, 2017.
- [16] E. M. S. de Castro, F. Giraud, B. Lemaire-Semail, and M. Amberg, “Vector controlled ultrasonic transducer applied to soft material mechanical impedance estimation,” in *2021 IEEE International Workshop of Electronics, Control, Measurement, Signals and their application to Mechatronics (ECMSM)*, IEEE, 2021, pp. 1–5.
- [17] G. Iannetti, L. Zambreau, and I. Tracey, “Similar nociceptive afferents mediate psychophysical and electrophysiological responses to heat stimulation of glabrous and hairy skin in humans,” *The Journal of physiology*, vol. 577, no. 1, pp. 235–248, 2006.