



HAL
open science

A Flexible Cloud-based HIL Testing of Batteries for Various Electrified Vehicles

Ronan German, T. Kalogiannis, Alain Bouscayrol, J. He, Florian Tournez, M. Bercibar, C. Husar, M. Ciocan, S. Costa, A. Genic, et al.

► **To cite this version:**

Ronan German, T. Kalogiannis, Alain Bouscayrol, J. He, Florian Tournez, et al.. A Flexible Cloud-based HIL Testing of Batteries for Various Electrified Vehicles. IEEE Transactions on Vehicular Technology, 2023, IEEE Transactions on Vehicular Technology, pp.1-10. 10.1109/tvt.2023.3337655 . hal-04327711

HAL Id: hal-04327711

<https://hal.univ-lille.fr/hal-04327711v1>

Submitted on 6 Dec 2023

HAL is a multi-disciplinary open access archive for the deposit and dissemination of scientific research documents, whether they are published or not. The documents may come from teaching and research institutions in France or abroad, or from public or private research centers.

L'archive ouverte pluridisciplinaire **HAL**, est destinée au dépôt et à la diffusion de documents scientifiques de niveau recherche, publiés ou non, émanant des établissements d'enseignement et de recherche français ou étrangers, des laboratoires publics ou privés.

A Flexible Cloud-based HIL Testing of Batteries for Various Electrified Vehicles

R. German, T. Kalogiannis, A. Bouscayrol, J. He, F. Tournez, M. Berecibar, C. Husar, M. Ciocan, S. Costa, A. Genic, B. Lemaire-Semail

Abstract— Power Hardware-in-the-loop (HIL) testing is increasing in the automotive industry for testing subsystems for new vehicles. Usually, the test is located in a unique place (stand-alone (local) HIL). The key-points for a vehicle manufacturer and subsystems suppliers are time and confidentiality. Using the cloud is a way to satisfy the both. Cloud model sharing is developed to spare time and cloud-based real-time simulation limits the access to the models to only certain variables. In this paper, a cloud-based power HIL testing is proposed using a cloud of vehicle models. The Energetic Macroscopic Representation (EMR) formalism is used to organize all the models. It facilitates the interconnections between the simulated and power tested subsystems. Two new batteries are experimentally tested, one for an electric vehicle, the other one for a plug-in hybrid vehicle. The same cloud is used and the power test facilities are located in two different locations. This shows the flexibility of the method.

Index Terms — Hardware-in-the-loop, electric vehicle, battery testing, energetic macroscopic representation, cloud-based simulation.

I. INTRODUCTION

FAST development of electrified vehicles is a challenge to limit the global warming [1]. Different vehicles are developed in that aim [2]: Battery Electric Vehicle (BEV) [3], Hybrid Electric Vehicles (HEV) [4] and Fuel Cell Vehicles (FCV) [5]. But their integration in the automotive market is still limited. New concepts must be developed to increase their performances and reduce their costs. However, the development of a completely new vehicle takes several years according to the V-model [6], with the development and validation phases. To speed up this development, digital tools are more and more integrated in the V-model [7]. Virtual digital prototypes enable to test the complete vehicle before any device building. Moreover, real-time simulation of a part of the vehicles is used in Hardware-In-the-Loop (HIL) testing [8] for

reliable tests of physical components or subsystems before integration in the real vehicle.

Co-simulation has been developed for development of advanced virtual vehicle prototypes [9][10]. In that case, several dedicated software packages are coupled. The interest of co-simulation is that each team can keep its dedicated software and expertise. Moreover, the confidentiality of new components or concept can be preserved as only interface variables are transmitted. The limitation of this approach is that each software has its own model organization (0D or 2D, structural or functional, etc.), and also its own solving procedures. Dedicated interfaces have been developed to enable interconnexion despite heterogeneity. This is the concept of FMI (Functional Mock-up Interface) which is applied to co-simulation [11] or parallel multi-step simulation [12]. This interface is difficult to develop and lead to supplementary computation time. This last point limits the use of co-simulation in HIL testing, which requires real-time simulation.

Another approach is to use a cloud of models that can be shared by different users [13]. This approach requires a common organization of the model and software that can be a high constraint. The positive impact of this common organization is to limit the need of the development of complex digital interfaces such as FMI. No computation time is lost for compatibility problem resolution. This is a decisive point for real-time simulation. The same model on the cloud can be used for virtual vehicle testing but also for HIL testing of one component. The confidentiality of the model can be preserved by using a black-box model with only inputs and outputs available for other models. An experience has been conducted by the PANDA European project in the development of a cloud of model [7]. The Energetic Macroscopic Representation (EMR) formalism [14] has been used. The EMR is a representation and not a model. The model is firstly chosen with assumptions depending on the objective [15]. The representation comes in a second time and consists in

Copyright (c) 2023 IEEE. Personal use of this material is permitted. However, permission to use this material for any other purposes must be obtained from the IEEE by sending a request to pubs-permissions@ieee.org. Manuscript received Apr. 2023; revised Sept. 2023; accepted Nov. 2023. This work was supported by the European Union's Horizon 2020 program under Grant agreement # 824256.

R. German, A. Bouscayrol, F. Tournez and B. Lemaire-Semail are with the L2EP Department, University of Lille, Lille, 5900, France, on leave from the (corresponding author, phone +33 (0)3-20-43-41-57; e-mail: Ronan.German@univ-lille.fr).

T. Kalogiannis, J. He, M. Berecibar are with the Moby group, Vrije University of Brussels, Brussels, 1050, Belgium (e-mail: Theodoros.kalogiannis@vub.be).

C. Husar and M. Ciocan are with Siemens Industry Software, Brasov, Zip code, Postcode, Romania (e-mail: author@siemens.com).

S. Costa and A. Genic are with Thyphoon HIL, Novi-Sad, Zip code, Postcode, Serbia (e-mail: author@typhoon.com)

organizing the equations defined by the model. EMR is a strict organization of any models with fixed inputs/outputs according to the causality [16] and power exchanges. This functional and strictly causal organization lead to reduce the computation time compared to a classical structural and non-causal organization. In [17], the simulation time gain has been quantified to 15%. Another key advantage of the EMR is that the control structure is deduced in a systematic and graphical way. A slight drawback of this EMR-based approach is not classical and some effort must be done to rewrite the model equations in a causal way.

This EMR-based cloud of models has been used for virtual testing of a BEV [18], a FCV [19] and a plug-in HEV [20]. Private models can be used with the remote property of the cloud. For example, for the plug-in HEV, the electrical machine model was confidential (no access to internal parameters), as it was an innovative electrical machine developed by Valeo company.

Hardware-In-the-Loop (HIL) testing is more and more used in automotive industry. HIL method consists in coupling a hardware part with a software part. The hardware under test thus interacts with a digital model of the rest of the system, simulated in real time [8]. For testing power components, a power interface is used to translate the signals in power and vice-versa [21][22]. The quality of HIL testing depends on the dynamics of the power interface, the model accuracy of the simulated part and the performances of the real-time simulator [23]. HIL testing has been used to test batteries [24], power converters [25][26], electric drives [27], hybrid powertrain and their energy management strategy [28], etc. These tests [24]-[28], have been achieved in a stand-alone configuration, i.e., with a local real-time simulator. The stand-alone HIL testing requires a real-time model of the non-tested part of the vehicle that can lead to a long development time. In stand-alone configuration, all models are required to be run locally that can lead to confidentiality issue. During the PANDA H2020 project, the EMR was used to organize BEV, FCV, HEV simulations and battery, e-drive and the complete electrical system of a P-HEV stand-alone HIL testing [29].

Cloud based HIL testing have been achieved since several years for electric grid applications [30]. Compared to stand-alone HIL testing, new constraints appear: the communication delay between the different sites, the associated jitter and the loss of messages [31]. The dynamics of the tested and simulated parts must be slower than the communication delay to avoid bad results or instability [30]. Using cloud-based power HIL tests is more recent for electrified vehicles. An experience has been conducted to test the anti-blocking system of a mechanical brake using HIL and a real-time model in a long-distance remote country (Germany/Japan) [32]. In [32] the authors suggest to use Kalman filter estimator to compensate the communication delay especially for intercontinental communications when the distance is growing.

A vehicle-in-the-loop has also been presented for HIL testing of a thermal engine and a battery, using a cloud connected to a real vehicle to recover the driver request on a real driving cycle [33]. These first experiences have dedicated organizations that are difficult to generalize.

A previous work has been achieved using the cloud of models of the PANDA project to simulate the Renault Zoe BEV and, in a second step, this model has been used for a stand-alone HIL testing of the battery [34].

The objective of the actual paper is to develop a cloud-based HIL battery testing for different electrified vehicles from a common cloud. The advantages are the confidentiality of the models (remote because of the cloud), the seamless interconnection and communication (because of the unique organization) and the gain in term of model development time (vehicle models already on the cloud). First, a new battery is tested for the Renault Zoe, but now the real-time simulation is operated in the cloud compared to [34]. Second, another battery is tested using this cloud-based HIL testing for a Plug-in HEV. This shows the flexibility of the method that can be applied directly to any battery for any vehicle. In both cases, a simulation team can develop a complete simulation in the Cloud. A testing team can thus use this simulation without redeveloping a vehicle model. Moreover, the confidentiality of some parameters will be preserved as the local testing team (or partner) has only access to exchange variables.

The organization of the cloud-based HIL testing is described in section II. Section III is devoted to the cloud-based HIL testing of a battery for a BEV. Section IV deals with the cloud-based HIL testing of another battery for a plug-in HEV.

II. HIL TEST ORGANIZATION

A. Unified simulation organization

The quality of power HIL testing depends on different factors. First, the testing interface should be as transparent as possible in order that the tested subsystem believes it is really connected to the rest of the vehicle. Second, the non-tested part must be simulated in real-time to impose the right dynamics and interaction to the tested subsystem. For cloud-based HIL testing, the communication delay must be negligible compared to the dynamics of the simulated subsystem to not affect the right interaction and avoid instability [31]. For all these reasons functional models respecting the natural causality can be relevant. In that aim, the EMR formalism [14] has been used to develop a cloud of models in the PANDA European project for virtual and real prototype testing [7]. EMR is a graphical formalism for model and control organizations of multi-physical energy conversion systems.

EMR is based on the interaction principle: all elements are connected by action and reaction variables whose product is the exchanged power. This property enables a physical and logical splitting between the subsystem under test, the power interface and the subsystem simulated in real time.

EMR is based on the causality principle: the outputs are a consequence of the inputs, with a delay; according to the natural causality. This property enables the use of classical solvers that leads to reasonable computation time. Moreover, the natural causality enables a clear definition of the power interface that has to interact in causal way with the tested real subsystem. A simplified EMR of an electric vehicle is described as an example (Fig. 1). The battery and the road are energy sources (green ovals). The electric drive (e-drive) and mechanical transmission (m-transmission) are conversion elements (orange circle and square). The vehicle chassis is an accumulation

element (crossed orange rectangle) with the velocity v_{ev} as output due to the causality principle.

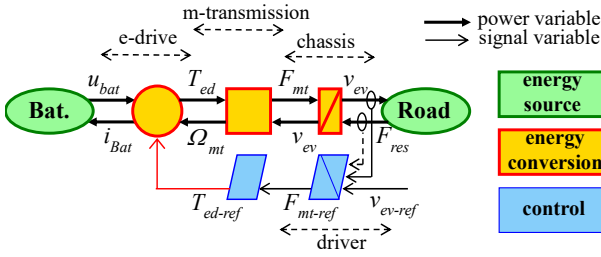

Fig. 1: example of EMR of a BEV

The vehicle control is depicted by light blue parallelograms, including a control loop which depicts the driver (needed for simulation). A more detailed EMR of this EV can be found in [35].

The interaction variables are: battery voltage u_{bat} and e-drive current i_{ed} , e-drive torque T_{ed} and m-transmission speed Ω_{mt} ; traction force F_{mt} and vehicle velocity v_{ev} ; vehicle velocity and resistive force F_{res} . The inputs and outputs of each subsystem are thus fixed from the natural causality of the elements (e.g., the battery imposes the voltage). Different models can be used for each subsystem, but their inputs and outputs must be maintained. An advanced battery modelling using EMR is presented in [36] and a more detailed model of the e-drive in [37].

B. Simulation organization

EMR libraries have been developed in MATLAB-Simulink [38], in Simcenter -Amesim © software [39] and other software [38]. Multilevel models of batteries and e-drive have been integrated for simulation of electrified vehicles in Simcenter -Amesim © [7]. Models of other subsystems (e.g., chassis or thermal engine) have also been developed. The models can then be connected to simulate various electrified vehicles. A cloud of model has been developed with Simcenter -Amesim © but it can be achieved in other software packages. Classical stand-alone simulation can be achieved by uploading the models from the cloud. Cloud-computing simulation can also be achieved.

C. Stand-alone HIL testing

Power Hardware-in-the-Loop testing aims to test a power subsystem in interaction with the simulation of other subsystems. Let us consider the test of an EV battery as an example (Fig. 2). The other parts of the system must be simulated in real time. The system is split into 2 parts that have to keep the same interactions (i.e., I/Os). The simulated systems consist in mathematical models (purple pictograms in Fig. 2), which generate signal variables. A power interface (e.g., power amplifier) has to interface the power tested subsystem with the virtual simulated subsystems. This power interface translates power variables into signal variables and vice-versa. It must be as transparent as possible. The dynamics of this power interface must be faster than the higher dynamics of the simulated part. The EMR leads to a clear definition of the power interface: it must be a current source to deliver the current to the battery from a reference current provided by the real-time model.

An EMR library has also been developed in Typhoon control center [40] which is a software dedicated to real-time simulation. A compilation tool has been developed between Simcenter -Amesim © and Typhoon software to enable a seamless transfer of EMR-based models.

D. Cloud-based HIL testing under a common framework

For cloud-based HIL testing, the test is split into 2 parts (Fig. 3). For any cloud-based power HIL testing, the power part (real system to test (battery), sensors and power interface) is in the local test facility. The rest can be simulated totally or partly in the cloud. For the presented method (battery power HIL testing) the traction model is simulated integrally on the cloud. This corresponds to the model of the vehicle to test (without the battery) and the vehicle control. This structure is flexible as any battery can be tested for any vehicle model. For the chosen partition simplicity, we simulate all the model in the cloud as the dynamic is slow ($\sim 1s$). Nevertheless, faster parts can be located on the cloud as long as the communication delay is negligible compared to the communication variable dynamics. The second condition is that the simulated part on the cloud must also run in real time to perform HIL testing. A vehicle model considering the main dynamics of the vehicle and a simplified electric drive model is sufficient for battery testing [36].

Simulation on the cloud has two advantages. First, nothing is shared between the two parts except the inputs and outputs. This guarantees confidentiality for the vehicle manufacturers.

This may encourage these manufacturers to propose cloud of models with appropriate levels of confidentiality. The second advantage is the gain of the development time: the vehicle model is developed once, can be used in simulation and HIL testing and can be shared with different partners.

In this paper, the cloud is located on a server in Paris, that contain Simcenter -Amesim©. The cloud computer characteristics are given in Table 1. Two local computers are used in Brussels and Lille. These local computers are Typhoon Electronic Control Units (ECU) (Table 2) connected to the cloud using an Ethernet link.

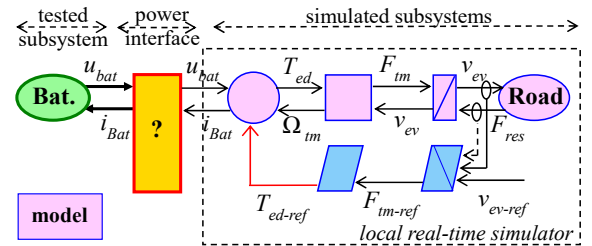

Fig. 2: Stand-alone HIL testing of the battery of a (BEV example)

The link between the two geographical points is established using a remote SSH tunnel facilitated by the open-source PuTTY software. The local HIL device (Typhoon) also requires a direct connection to the internet. PuTTY allows for the configuration of necessary IP addresses and target ports to facilitate data exchange. Data exchange takes place using the standardized Modbus TCP/IP protocol.

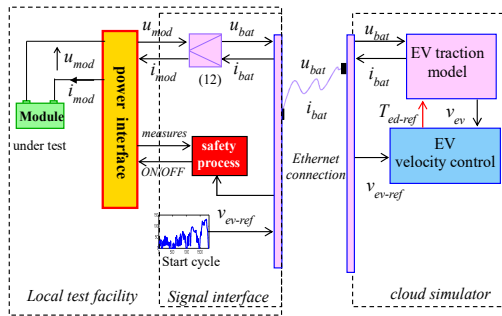

Fig. 3: Cloud-based HIL testing of the battery for a vehicle

This protocol blends the advantages of bus type communication with the structures of IP networks. It is an open, reliable, and standardized communication protocol based on the client-server model, with a relatively straightforward setup. Furthermore, it is equipped to identify lost or corrupted packets and provide automated solutions through mechanisms "Cyclic Redundancy Check" (CRC). On the server side, the Simcenter-Amesim© software uses a Shared Memory (SHM) block combined with a Python script, interfacing the Modbus client with the SHM block. This arrangement enables the reading and writing of data to memory, as well as the conversion of data into an appropriate format for transmission. For network confidentiality and safety concerns, the server only allows connections that have been pre-approved, thereby preventing any unauthorized connections to the server (authorization of IP addresses through the firewall, in both directions). Additionally, knowledge of the data exchange port is necessary for communication. Finally, the data is encrypted, making it difficult to intercept during transit.

Different tests have been achieved to estimate the communication delay between the cloud computer and the local computers. The maximal delays are 30 ms for the Lille connection and 60 ms for the Brussels connection.

To prevent various problems due to remote testing (such as distortion, instabilities, power run-out...) the communication delay has to be negligible in comparison to the variation time of the variables at the interface between the local test facility and the cloud one (battery current/voltage in our case). The methodology to prevent such problems is described below.

- First, the communication delay is measured by sending signals to the cloud and waiting for a confirmation of arrival. In our case, the average communication delay is 30 ms for Lille and 60 ms for Brussels.

- Second, the dynamic of the studied system (the vehicle model) is identified. In our case, when a driver presses the acceleration pedal, it gives a torque reference that is converted to a current imposed to the battery. The global dynamics of the vehicle model is a second or more.

- Third, the communication delay and the model dynamics are compared. In our case, the battery current variation is more than 10 times slower than the communication delay. So, for the battery power HIL testing, this delay can be considered negligible.

- Fourth, a pure real-time simulation test (using only virtual component) is performed between the local facility and the cloud before power HIL testing. In our case, this test has

confirmed that there is no impact of the communication delay on the simulation.

- Finally, if all the previous checks confirm that a test is feasible, then the power HIL testing can be realized.

The power interface is also a critical component. It emulates the power on the tested subsystem. As the traction subsystem of the vehicle is an equivalent current source the power interface is a current source. Two variables are important to properly emulate.

- The current level must be the same as in the battery in the real vehicle.
- The dynamic of the power interface must be lower than the dynamics of the model.

Last point, using the same model organization in the cloud and the Typhoon controller board makes the development of an FMI unnecessary.

Table 1: characteristic of the cloud computer

Core processor	intel Xeon Platinum 258C
Number of cores	Dual cores (2.5 GHz)
RAM	4 GB
Selected communication port	Ethernet
Communication protocol	MODBUS TCP/IP

Table 2: characteristics of the local real-time signal interface

Processor	Typhoon HIL606 (Zyniq-7 SoC)
Selected in/out delay	20 μ s
Digital I/Os	64 DIs/64 DOs, 5V logic
Analog I/Os	32 AIs/64 AOs, +/- 10V
Selected communication port	Ethernet
Communication protocol	MODBUS TCP/IP

III. HIL BATTERY TESTING FOR A BEV

A. Studied Vehicle

The BEV is Renault Zoe (Fig. 4.a) of 1468 kg. Its traction system is composed of a NMC Li-ion battery (22 kWh, 350V), a 65 kW electric drive (inverter and synchronous machine) and a classical mechanical transmission. A new battery composed of 7 Bluways modules of 5 kWh (Table 3) is studied (Fig. 4.b). The battery nominal voltage is the same than the original one and the total energy is higher (35 kWh).

Table 3: characteristics of a single Bluways module

Voltage (min/max)	43 V – 61 V
Current (charge/discharge)	1200 A / 240 A
Total energy	5 kWh
Number of cells	30
Module topology	15 in series / 2 in parallel
Weight	35 kg

B. EMR and control of the vehicle

The EMR of the vehicle (Fig. 5) has been already proposed in [35]. It is assumed an equivalent wheel (nor curve neither wheel slip) and a static model of the e-drive (considering the efficiency). In terms of energy consumption this model is validated with only 3% of errors compared to experimental tests on the real vehicle [35].

The battery, the mechanical brake and the road are energy sources (green oval pictograms) imposing the battery voltage u_{bat} , the braking force F_{mb} and the resistive force F_{res} .

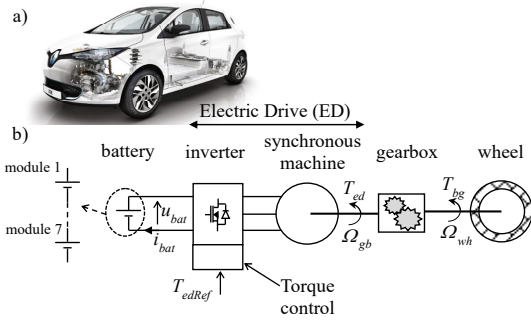

Fig. 4: Studied EV: a) vehicle, b) structural scheme

The electric drive is modelled by a static model (multi-domain conversion, orange circle) that imposes the torque T_{ed} and the current i_{ed} from the torque reference T_{ed-ref} , the battery voltage and the rotation speed Ω_{ed} , with η_{ed} the drive efficiency:

$$\begin{cases} T_{ed} = T_{ed-ref} \\ i_{bat} = \frac{T_{ed}\Omega_{ed}}{u_{bat}\eta_{ed}^k} \end{cases} \text{ with } \begin{cases} k = 1 \text{ if } T_{ed}\Omega_{ed} > 0 \\ k = -1 \text{ if } T_{ed}\Omega_{ed} < 0 \end{cases} \quad (1)$$

The gearbox is a conversion element (orange square) which imposes the torque T_{gb} and speed Ω_{gb} from the drive torque and wheel speed Ω_{wh} , with η_{gb} its efficiency.

$$\begin{cases} T_{gb} = k_{gb}T_{ed}\eta_{gb}^k \\ \Omega_{gb} = k_{gb}\Omega_{wh} \end{cases} \text{ with } \begin{cases} k = 1 \text{ if } T_{gb}\Omega_{wh} > 0 \\ k = -1 \text{ if } T_{gb}\Omega_{wh} < 0 \end{cases} \quad (2)$$

The wheel is a conversion element (orange square) which imposes the traction force F_{wh} and the wheel speed from the torque T_{gb} and the velocity v_{ev} , with R_{wh} the wheel radius:

$$\begin{cases} F_{wh} = 1/R_{wh}T_{gb} \\ \Omega_{wh} = 1/R_{wh}v_{ev} \end{cases} \quad (3)$$

The vehicle chassis is composed of 2 elements. A coupling element (overlapped orange square) couples the traction force and the braking force F_{br} , assuming an ideal braking. The resulting force is F_{tot} .

$$F_{tot} = F_{wh} + F_{br} \quad (4)$$

$$F_{br} = F_{br-ref} \quad (5)$$

An accumulation element (crossed orange rectangle) imposes the vehicle velocity as a state variable from the total and resistive forces F_{res} , with M the vehicle dynamical mass:

$$F_{tot} - F_{br} = M \frac{d}{dt} v_{ev} \quad (6)$$

The resistive force depends on the velocity, with A the friction coefficient and B the aerodynamic coefficient:

$$F_{res} = Av_{ev} + Bv_{ev}^2 \quad (7)$$

A control scheme can be directly deduced from the inversion of the EMR. The accumulation element (6) is inverted by a closed-loop control to obtain the $F_{tot-ref}$ from vehicle reference v_{ev-ref} , with $C(t)$ a controller:

$$F_{tot-ref} = C(t)(v_{ev-ref} - v_{ev-meas}) \quad (8)$$

The coupling element (4) is inverted to distribute $F_{tot-ref}$ in F_{wh-ref} and F_{br-ref} , with k_d a distribution input defined by the strategy level.

$$\begin{cases} F_{br-ref} = k_d F_{tot-ref} \\ F_{wh-ref} = (1 - k_d) F_{tot-ref} \end{cases} \quad (9)$$

Both conversion elements, (2) and (3), are directly inverted to obtain the e-drive torque reference, T_{ed-ref} :

$$T_{gb-ref} = R_{wh} F_{wh-ref} \quad (10)$$

$$T_{ed-ref} = 1/k_{gb} T_{gb-ref} \quad (11)$$

The EMR and control are presented in Fig. 5. More details can be found in [35]. A cloud simulation of the vehicle is also proposed in [34].

C. Cloud-based HIL set-up

Now, the model is split into 4 parts (Fig. 6): the battery under test, the power interface, the signal interface and the cloud simulation (traction model and control). The cloud is located in Paris and the testing bench is in Brussels (275 km). The cloud and the local interface parameters are set to the same values as in § II.D.

The power interface is ensured by a PEC SBT8050 battery cycler (maximum of DC 80V, $\pm 0.05\%$ measurement accuracy, Fig. 7). A CAN bus communication is established between the local real-time simulator (Typhoon ECU) and the PEC cycler.

Due to the power interface limitations, a single real module is tested. It represents a part of the vehicle battery. As the vehicle battery is composed of 7 modules in series, a power adaptation is inserted in the local simulator:

$$\begin{cases} u_{bat} = 7u_{mod} \\ i_{bat} = i_{mod} \end{cases} \quad (12)$$

Where u_{mod} and i_{mod} are the voltage and current of one module. u_{bat} and i_{bat} are the voltage and current of the whole battery.

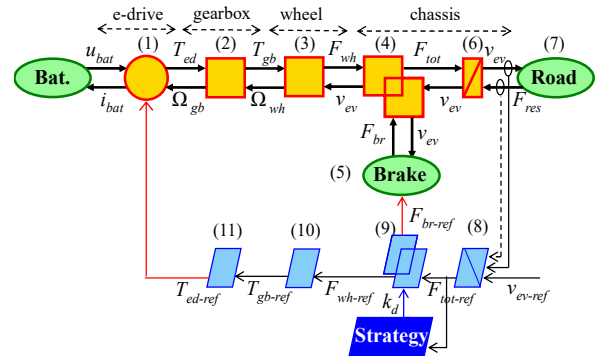

Fig. 5: EMR of the traction of the studied EV

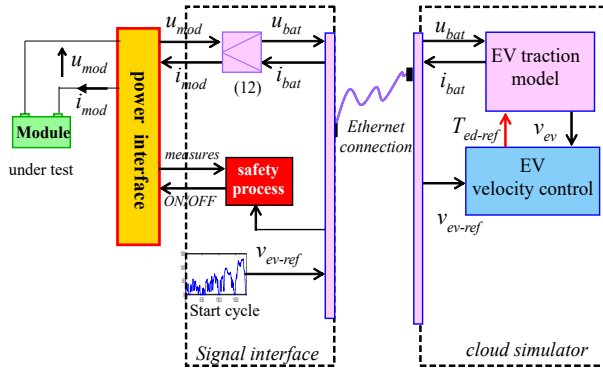

Fig. 6: Organization of the HIL testing for BEV

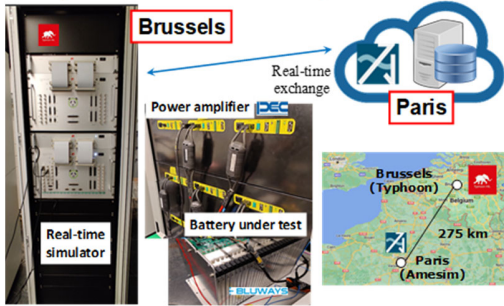

Fig. 7: Organization of the HIL testing for BEV

In this way, the tested module has the same voltage and current than in the real vehicle. A safety process is developed in the local simulator. An emergency stop is provided when the Ethernet connection is lost. Moreover, mechanical circuit breakers and fuses are utilized as passive safety elements. The battery module under test in Brussels is connected to the power interface.

D. Experimental results

A real urban velocity profile is used as an input for the cloud simulation part (Fig. 8. a). The cloud simulation leads to a reference e-drive current sent to the local simulator, which generates the module current (Fig. 8. b). The power amplifier imposes this reference current to the module that leads to an evolution of the voltage (Fig. 8. c). The SoC of the module is also a consequence of the load current (Fig. 8. d).

These experimental results validate the use of this new battery for the Renault Zoe and the proposed driving cycle.

IV. HIL BATTERY TESTING FOR A PLUG-IN HEV

A. Studied Vehicle and tested battery

The studied Plug-in Hybrid Electric Vehicle (P-HEV) is a demo car (Fig. 9) of 1400 kg with an Internal Combustion Engine (ICE) of 96 kW. This vehicle has been retrofitted from a gasoline car (Peugeot 308 SW) by including 2 e-drives (4 kW in the front and 25 kW in the rear) and a low-voltage battery (48V, 5 kWh) by Valeo [20]. The test is focused on a new 48V/10 kWh battery in replacement of the original one. It is composed of 5 Yuasa modules connected in parallel (Fig. 9). The parameters of a Yuasa module are given in Table 4.

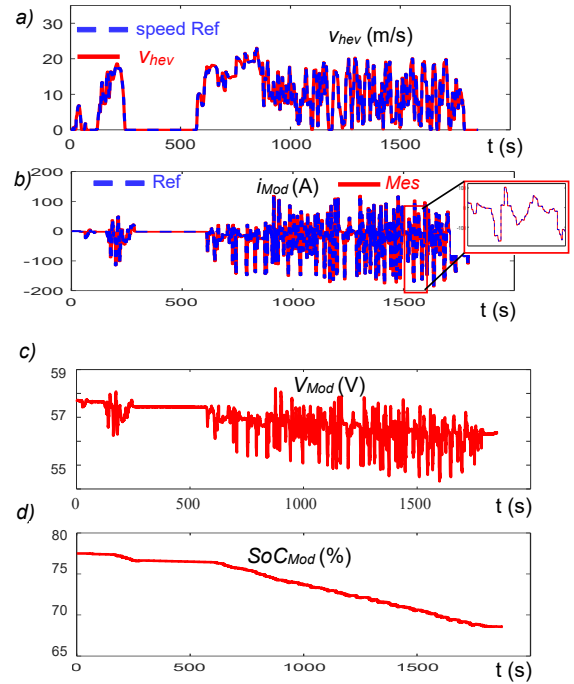

Fig. 8: Experimental results: a) velocity, b) module current, c) voltage, d) SoC

Table 4: characteristic of a single Yuasa module

Voltage (min/max)	33 V – 50.4 V
Current (charge/discharge)	300 A / 47.5 A
Total energy	2 kWh
Number of cells	12
Module topology	12 in series / 1 branch
Weight	17 kg

B. EMR and control of the vehicle

The EMR of the vehicle (Fig. 10) has already been proposed in [20]. It is a complete model including a thermal engine and two electrical drives. A specific Energy Management Strategy (EMS) has been developed by Valeo to reduce the fuel consumption by adapted the distribution inputs and gearbox ratios. It is kept confidential on the cloud.

An equivalent wheel, static models of the e-drives and the ICE (including the respective efficiencies) are considered. The clutches are considered as ideal. In terms of energy consumption this model leads to only 5% of errors compared to a more complex model [20].

The EMR (Fig. 10) is built from the different equations (13) to (23). The control equations are also obtained from an inversion of the model equations. A closed-loop control with a controller $C(t)$ is required for the inversion of the accumulation element (23). Distribution inputs are required for the inversion of the coupling elements: k_{d1} distributes the electrical and mechanical braking forces (26); k_{d2} distributes the wheel forces (27); k_{d3} distributes the ICE and the e-drive torques (31).

For all equations j refers to the traction (number 1 for the front or 2 for the rear) and ref means reference.

$$i_{bat} = i_{ed1} + i_{ed2} \quad (13)$$

Where i_{bat} is the battery current and i_{ed1} and i_{ed2} are the current coming from electric drive 1 and 2.

$$\begin{cases} T_{edj} = T_{edj-ref} \\ i_{edj} = \frac{T_{edj}\Omega_{gbj}}{u_{bat}\eta_{edj}^k} \end{cases} \text{ with } \begin{cases} k = 1 \text{ if } T_{edj}\Omega_{gbj} > 0 \\ k = -1 \text{ if } T_{edj}\Omega_{gbj} < 0 \end{cases} \quad (14)$$

T_{edj} refers to the electrical drive torque, Ω_{gbj} is the rotation speed at the gearbox input and η_{edj} is the efficiency of the electric drive. The variable k is depending on the power transfer (traction or braking mode).

$$T_{tot} = T_{ed1} + T_{ice} \quad (15)$$

Where T_{Tot} is the total torque coming from the electric drive 1 T_{ed1} and the internal combustion engine T_{ice} .

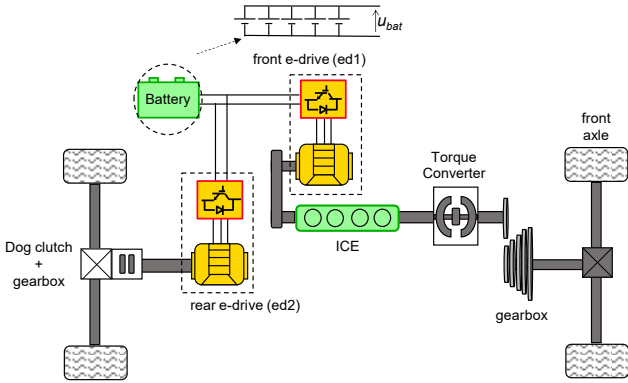

Fig. 9 : Studied P-HEV

$$\begin{cases} T_{gb1} = k_{gb1}T_{tot}\eta_{bg1}^k \\ \Omega_{gb1} = k_{gb1}\Omega_{wh1} \end{cases} \text{ with } \begin{cases} k = 1 \text{ if } T_{gb1}\Omega_{wh1} > 0 \\ k = -1 \text{ if } T_{gb1}\Omega_{wh1} < 0 \end{cases} \quad (16)$$

$$\begin{cases} T_{gb2} = k_{gb2}T_{ed2}\eta_{gb2}^k \\ \Omega_{gb2} = k_{gb2}\Omega_{wh2} \end{cases} \text{ with } \begin{cases} k = 1 \text{ if } T_{gb2}\Omega_{wh2} > 0 \\ k = -1 \text{ if } T_{gb2}\Omega_{wh2} < 0 \end{cases} \quad (17)$$

Where T_{gb1} is the Torque at the gearbox 1 output, k_{gb1} is the gearbox 1 ratio and η_{bg1}^k is the efficiency of the gearbox 1. For gearbox 2 the same equation is used, but the torque comes from a unique electric drive (T_{gb2})

$$\begin{cases} F_{whj} = 1/R_{wh}T_{gbj} \\ \Omega_{whj} = 1/R_{wh}v_{ev} \end{cases} \quad (18)$$

Where F_{whj} is the force applied to the wheels, R_{wh} is the radius of the wheels and v_{ev} is the velocity of the vehicle.

$$F_{tot1} = F_{wh1} + F_{wh2} \quad (19)$$

Where F_{tot1} is the total traction force.

$$F_{tot2} = F_{tot1} + F_{br} \quad (20)$$

Where F_{tot2} is the total force including the braking force F_{br} .

The control of the ICE and the brakes are represented by tunable source elements in EMR.

$$T_{ice} = T_{ice-ref} \quad (21)$$

$$F_{br} = F_{br-ref} \quad (22)$$

The equation of the vehicle dynamic and resistance to the movement are given below.

$$F_{tot2} - F_{br} = M \frac{d}{dt} v_{hev} \quad (23)$$

$$F_{res} = Av_{hev} + Bv_{hev}^2 \quad (24)$$

The control equations are given below. They correspond to the light blue pictograms in Fig. 10.

$$F_{tot2-ref} = C(t)(v_{hev-ref} - v_{hev-meas}) \quad (25)$$

$$\begin{cases} F_{br-ref} = k_{d1}F_{tot2-ref} \\ F_{tot1-ref} = (1 - k_{d1})F_{tot2-ref} \end{cases} \quad (26)$$

$$\begin{cases} F_{wh1-ref} = k_{d2}F_{tot1-ref} \\ F_{wh2-ref} = (1 - k_{d2})F_{tot1-ref} \end{cases} \quad (27)$$

$$T_{gbj-ref} = R_{wh}F_{whj-ref} \quad (28)$$

$$T_{ed2-ref} = 1/k_{gb2}T_{gb2-ref} \quad (29)$$

$$T_{tot-ref} = 1/k_{gb1}T_{gb1-ref} \quad (30)$$

$$\begin{cases} T_{ice-ref} = k_{d3}T_{tot-ref} \\ T_{ed1-ref} = (1 - k_{d3})F_{tot-ref} \end{cases} \quad (31)$$

The simulation of the vehicle using this EMR model has been achieved in [20] and a stand-alone power HIL testing of a Bluways battery in [41]. But these tests were performed by Valeo to keep the confidentiality of the electric drive and the energy management strategy. A new Yuasa battery will be now tested in another site, and the complete model cannot be transmitted to the testing site to preserve the confidentiality. The cloud will be used in that aim. The different communication variables are shown in Fig. 11. The communication between I/Os is ensured by an Ethernet bidirectional connection. The cloud is located in Paris and the testing bench is in Lille (220 km distance).

The chosen power interface (Fig. 12) is a Cinergia Grid emulator AC&DC 60 kVA [42]. It is a controllable current source able to deliver a +187A/-187A in DC mode for an analog control input between 10V/-10V analog signal. The maximum power is 54 kW. The current delay added by the power interface is about 5 ms so it is negligible compared to the dynamics of the battery current (1s).

Due to the power interface limitations, a single module is tested. As the P-HEV battery is composed of 5 modules in parallel, a power adaptation is inserted in the local ECU:

$$\begin{cases} u_{mod} = u_{bat} \\ i_{mod} = i_{bat}/5 \end{cases} \quad (32)$$

The tested module thus receives the same current than a module in the real vehicle. Moreover, a safety process is developed in the local simulator to prevent any issue. A software emergency stop is sent when power limitations are achieved or the Ethernet connection is lost. A hardware emergency stop is also provided, as well as battery fuse, circuit breaker and disconnecter.

C. Experimental results

The test consists in a WLTC (Worldwide harmonized Light vehicles Test Cycles) class 3 (Fig. 13. a). This is an extra-urban standard driving cycle. The control in the cloud aims to follow the velocity (zoom of Fig. 13. a). It also delivers the current reference to the local ECU.

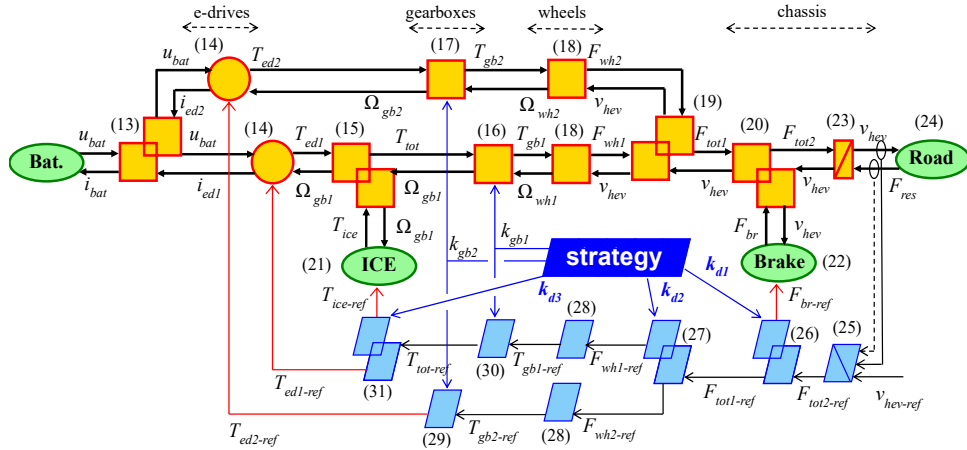

Fig. 10: EMR of the traction of the studied P-HEV

D. Cloud-based HIL testing set-up

First the model is split into different parts (Fig. 11): the new battery under test, a power interface, a local ECU as digital interface and the vehicle model to be simulated in real time on the cloud. In that way, the electrical drive model and the energy management strategy are not shared

The simulated current and voltage are exchanged through the Ethernet connection. From the local test, the module current reference is generated by the power amplifier (Fig. 13.b). The current reference defined from the cloud is well achieved by the power amplifier (zoom in Fig. 13.b). The measured voltage of the module (Fig. 13. c) is sent to the real-time cloud simulation part. The SoC (Fig. 13.d) decreases from 60% to 50.9 %. (Fig. 13.d). Moreover, the battery temperature is also tested (Fig. 13.e).

These experimental results validate the use of the tested battery for this P-HEV and this driving cycle. The battery behavior can also be tested for more driving cycles and also auxiliary loads.

V. CONCLUSION

A unified model organization has been proposed to achieve cloud-based power HIL testing of different batteries for different vehicles. This has been achieved using a common cloud of model used for both pure simulation and HIL testing.

The EMR formalism is used as a guideline for model and HIL organization. The key advantage of the EMR is to specify the inputs and outputs variables of every subsystems which is decisive for partition and interconnection of local and cloud parts. The EMR imposes a strict formalism for modelling and control due to the integral causality and mirror effect.

A new battery module is tested for the Renault Zoe using a HIL platform in Brussels and the cloud in Paris. Another battery module is also tested for a P-HEV using a HIL platform in Lille and the same cloud in Paris. For both tests the power part is local while the models of the vehicles run in real-time on the cloud. This ensures confidentiality as the local test facility has no access to the internal parts of the vehicle models. This method is directly generalizable and scalable to any larger/smaller vehicle and battery as long the power interface is able to supply the tested battery at the same amount of power than in the emulated vehicle.

Such a cloud of vehicle models can be shared by different entities for HIL testing of different parts of a vehicle without a need of redeveloping models. This means a gain of time in vehicle development.

From the EMR of the studied system, different testing possibilities can be deduced in a systematical way because of the input/ output organization. The condition is, the communication delay is short compared to the variables implied in data exchange. For example, future works could thus test an electric drive of the same vehicle using the cloud-based HIL method. That highlights the flexibility of the method which can be applied to any vehicle and any subsystems.

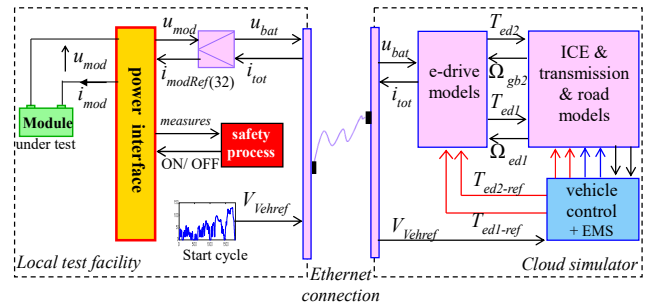

Fig. 11: Organization of the HIL testing for P-HEV

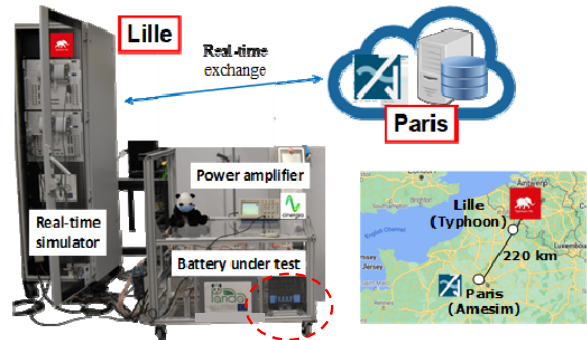

Fig. 12: Experimental set-up of the HIL testing for P-HEV

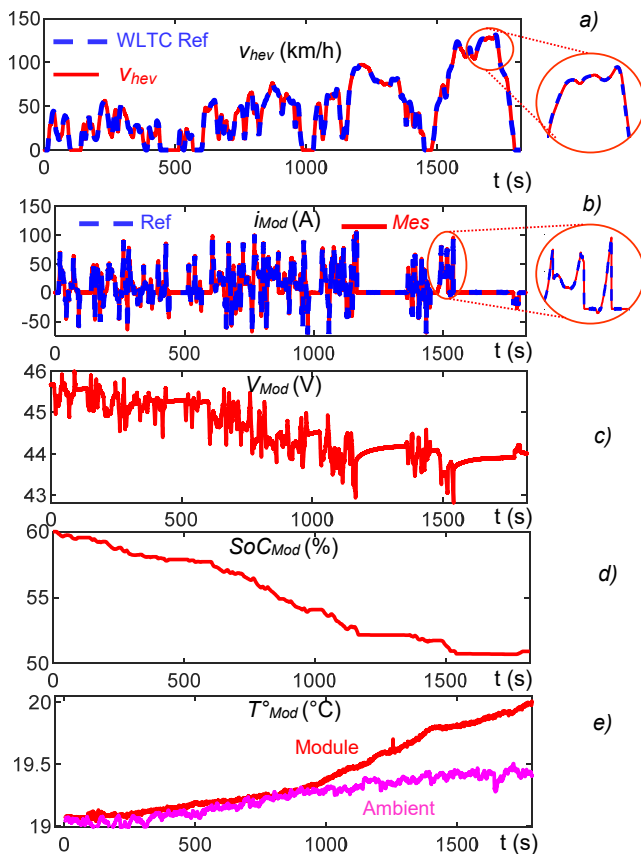

Fig. 13: Experimental results: a) velocity, b) module current, c) voltage, d) SoC, e) temperatures

ACKNOWLEDGMENT

This work has been realized within the framework of the PANDA project which has received funding from the European Union's Horizon 2020 research and innovation program under grant agreement no. 824256 (PANDA) and the VUMOPE project of CPER-ELSAT of region Hauts-de-France.

REFERENCES

- [1] International Energy Agency, "Global EV Outlook 2021", 2021.
- [2] C. C. Chan, A. Bouscayrol, K. Chen, "Electric, Hybrid and Fuel Cell Vehicles: Architectures and Modeling", *IEEE transactions on Vehicular Technology*, vol. 59, no. 2, pp. 589-598, February 2010, DOI: 10.1109/TVT.2009.2033605.
- [3] Z. Li, A. Khajepour, K. Song, "A comprehensive review of the key technologies for pure electric vehicles," *Energy*, vol. 182, pp. 824-839, Sept. 2019, doi: 10.1016/j.energy.2019.06.077.
- [4] M. Ehsani, K. V. Singh, H. O. Bansal and R. T. Mehrjardi, "State of the Art and Trends in Electric and Hybrid Electric Vehicles," in *Proceedings of the IEEE*, vol. 109, no. 6, pp. 967-984, June 2021, doi: 10.1109/JPROC.2021.3072788.
- [5] D. Shen, C. -C. Lim and P. Shi, "Fuzzy Model Based Control for Energy Management and Optimization in Fuel Cell Vehicles," in *IEEE Transactions on Vehicular Technology*, vol. 69, no. 12, pp. 14674-14688, Dec. 2020, doi: 10.1109/TVT.2020.3034454.
- [6] B. Liu, H. Zhang, S. Shu, "An incremental, V-Model process for automotive development", ASPEC'16, December 2016, Hamilton (New-Zeland)
- [7] A. Bouscayrol, A. Lepoutre, C. Irimia, C. Husar, J. Jagueumont, A. Lièvre, C. Martis, D. Zuber, V. Blandow, F. Gao, W. Van Dorp, G. Sirbu, J. Lecoutere, "Power Advanced N-level Digital Architecture for models of

- electrified vehicles and their components", in *Transport Research Arena 2020*, Helsinki (Finland), April 2020.
- [8] A. Bouscayrol, "Hardware-In-the-Loop simulation", *Industrial Electronics Handbook*, 2nd edition, Chapter 33, CRC Press, Chicago, March 2011, pp. 33-1/33-15, ISBN 978-1-4398-0287-8.
- [9] M. Datar, I. Stanculescu, D. Negrut, "A co-simulation environment for high-fidelity virtual prototyping of vehicle systems", *International Journal of Vehicle Systems Modelling and Testing*, Vol. 7, No. 1, pp. 64-72, Feb. 2012.
- [10] C. Gomes et al., "Co-simulation: a survey", *ACM Computing Surveys*, Vol. 51, no. 3, ref 49, pp 1-33, <https://doi.org/10.1145/3179993>.
- [11] L. I. Hatledal, A. Styve, G. Hovland and H. Zhang, "A Language and Platform Independent Co-Simulation Framework Based on the Functional Mock-Up Interface," *IEEE Access*, vol. 7, pp. 109328-109339, 2019, doi: 10.1109/ACCESS.2019.2933275.
- [12] M. Cai, H. Gras, J. Mahseredjian, E. Rutovic, A. El-Akoum, "Functional Mock-Up Interface-Based Approach for Parallel and Multistep Simulation of Electromagnetic Transients", *IEEE Trans. Power Deliv.*, vol. 33, no. 6, pp. 2978-2988, Dec. 2018, doi: 10.1109/TPWRD.2018.2860586
- [13] C. T. Blakley et al. "Engineering resilient systems cloud computing architecture (ECCA): a collaborative and secure analysis framework", *The Journal of Defense Modeling and Simulation: Applications, Methodology, Technology*, Vol. 19, no. 3, October 2020, <https://doi.org/10.1177/1548512920960539>.
- [14] A. Bouscayrol, J. P. Hautier, B. Lemaire-Semail, "Graphic Formalisms for the Control of Multi-Physical Energetic Systems", *Systemic Design Methodologies for Electrical Energy*, Chapter 3, ISTE Willey editions, October 2012, DOI: 10.1002/9781118569863.ch3.
- [15] C. Mayet, L. Horrein, A. Bouscayrol, P. Delarue, J. N. Verhille, E. Chatot, B. Lemaire-Semail, "Comparison of different models and simulation approaches for the energetic study of a subway", *IEEE transactions on Vehicular Technology*, Vol. 63, no. 2, February 2014, pp. 556-565, DOI: 10.1109/TVT.2013.2280727
- [16] I. Iwasaki, H.A. Simon, "Causality and model abstraction", *Artificial Intelligence*, vol. 67, pp. 143-194, 1994, DOI: 10.1016/0004-3702(94)90014-0.
- [17] C. Husar et al., "Comparison of Energetic Macroscopic Representation and Structural Representation on EV Simulation under Simcenter Amesim," 2019 IEEE Vehicle Power and Propulsion Conference (VPPC), Hanoi, Vietnam, 2019, pp. 1-6, doi: 10.1109/VPPC46532.2019.8952347.
- [18] C. Husar, E E Raclaru, A. Desrevaux, G. M. Sirbu, C. Irimia, M. Grovu, A. Bouscayrol, N. Boicea, M. Ponchnat, "Simcenter Amesim virtual validation of a BEV using EMR methodology", *IEEE-VPPC'21*, Gijon (Spain), October 2021
- [19] A. Elkamel, E. -E. Răclaru, W. Lhomme, D. Chqrenko and F. Gao, "Model Reduction of a Fuel Cell Vehicle using Energetic Macroscopic Representation under Simcenter Amesim," *IEEE-VPPC'22*, Gijon (Spain), October 2021.
- [20] F. Tournez, R. Vincent, W. Lhomme, S. Roquet, A. Bouscayrol, M. Ahmed, B. Lemaire-Semail, A. Lievre, "Difference between average efficiency and efficiency map of the electric drive on fuel saving estimation for P-HEV", *IEEE-VPPC'22*, Gijon (Spain), October 2021.
- [21] G. Lauss, M. O. Faruque, K. Schoder, C. Dufour, A. Viehweider, J. Langston, "Characteristics and Design of Power Hardware-in-the-Loop Simulations for Electrical Power Systems", *IEEE Trans. Ind. Electron.*, vol. 63, no. 1, pp. 406-417, Jan. 2016, DOI: 10.1109/TIE.2015.2464308.
- [22] K. Ma, S. Xia, Y. Qi, X. Cai, Y. Song, F. Blaabjerg, « Power-Electronics-Based Mission Profile Emulation and Test for Electric Machine Drive System—Concepts, Features, and Challenges », *IEEE Trans. Power Electron.*, vol. 37, no. 7, pp. 8526-8542, July. 2022, DOI: 10.1109/TPEL.2022.3149996.
- [23] K. Upamanyu, G. Narayanan, "Improved Accuracy, Modeling, and Stability Analysis of Power-Hardware-in-Loop Simulation With Open-Loop Inverter as Power Amplifier", *IEEE Trans. Ind. Electron.*, vol. 67, no. 1, pp. 369-378, Jan. 2020, DOI: 10.1109/TIE.2019.2896093.
- [24] Y. Zhang, R. Xiong, H. He, W. Shen, "Lithium-Ion Battery Pack State of Charge and State of Energy Estimation Algorithms Using a Hardware-in-the-Loop Validation", *IEEE Trans. Power Electron.*, vol. 32, no. 6, pp. 4421-4431, June 2017, DOI: 10.1109/TPEL.2016.2603229.
- [25] S. Grubic, B. Amlang, W. Schumacher, A. Wenzel, "A High-Performance Electronic Hardware-in-the-Loop Drive-Load Simulation Using a Linear Inverter," *IEEE Trans. Ind. Electron.*, vol. 57, no. 4, pp. 1208-1216, April. 2010, DOI: 10.1109/TIE.2009.2037656.

- [26] N. Sharma, G. Mademlis, Y. Liu, J. Tang, "Evaluation of Operating Range of a Machine Emulator for a Back-to-Back Power-Hardware-in-the-Loop Test Bench", *IEEE Trans. Ind. Electron.*, vol. 69, no. 10, pp. 9783-9792, Oct. 2022, DOI: 10.1109/TIE.2022.3142421
- [27] S.C. Oh, "Evaluation of motor characteristics for hybrid electric vehicles using the hardware-in-the-loop concept", *IEEE Trans. Veh. Technol.*, vol. 54, no. 3, pp. 817 - 824, May 2005, DOI: [10.1109/TVT.2005.847228](https://doi.org/10.1109/TVT.2005.847228)
- [28] H. Zhang, Y. Zhang, C. Yin, "Hardware-in-the-Loop Simulation of Robust Mode Transition Control for a Series-Parallel Hybrid Electric Vehicle", *IEEE Trans. Veh. Technol.*, vol. 65, no. 3, pp. 1059-1069, March 2016, DOI: 10.1109/TVT.2015.2486558.
- [29] A. Bouscayrol, G. M. Sirbu, A. Lepoutre, "Impact Analysis of virtual and real testing of electrified vehicles", PANDA H2020 GA# 824256, D6.6 Deliverable, public report, June 2022, [Online] available: <https://project-panda.eu/> (June 2022).
- [30] A. Monti *et al.*, "A Global Real-Time Superlab: Enabling High Penetration of Power Electronics in the Electric Grid", *IEEE Power Electron. Mag.*, vol. 5, n^o. 3, pp. 35-44, Sept. 2018, DOI: 10.1109/MPEL.2018.2850698.
- [31] F. Zhang, Y. Sun, L. Cheng, X. Li, J. H. Chow, W. Zhao, "Measurement and Modeling of Delays in Wide-Area Closed-Loop Control System", *IEEE Trans. Power Syst.*, vol. 30, no. 5, pp. 2426-2433, Sept. 2015, DOI: 10.1109/TPWRS.2014.2359773
- [32] V. Schreiber *et al.*, "Shared and Distributed X-in-the-Loop Tests for Automotive Systems: Feasibility Study", *IEEE Access*, vol. 6, p. 4017-4026, 2018, DOI: 10.1109/ACCESS.2017.2789020.
- [33] Y. Zhang, S. Lu, Y. Yang, Q. Guo, "Internet-Distributed Vehicle-in-the-Loop Simulation for HEVs", *IEEE Trans. Veh. Technol.*, vol. 67, no. 5, pp. 3729-3739, Mai 2018, DOI: 10.1109/TVT.2018.2803088.
- [34] R. German, F. Tournez, A. Desrevaux, A. Bouscayrol, C. Husar, M. Ciocan, A. Genic, D. Zuber, "Full Power constraints HiL Setup for Battery Module Testing in Electric Vehicles", *IEEE-VPPC'21*, Gijon (Spain), October 2021, DOI: 10.1109/VPPC53923.2021.9699218
- [35] A. Desrevaux, A. Bouscayrol, R. Trigui, E. Castex, J. Klein, "Impact of the Velocity Profile on Energy Consumption of Electric Vehicles", *IEEE transactions on Vehicular Technology*, Vol. 68, DOI: 10.1109/TVT.2019.2949215, no.8, pp. 11420-11426, December 2019.
- [36] R. German, S. Shili, A. Desrevaux, A. Sari, P. Venet and A. Bouscayrol, "Dynamical Coupling of a Battery Electro-Thermal Model and the Traction Model of an EV for Driving Range Simulation", *IEEE transactions on Vehicular Technology*, Vo. 69, no. 1, January 2020, pp. 328-337, DOI: 10.1109/TVT.2019.2955856
- [37] A. Desrevaux, M. Ruba, A. Bouscayrol, G. Sirbu, C. Martis, "Comparisons of models of electric drives for electric vehicles", *IEEE-VPPC'19*, Hanoi (Vietnam), October 2019.
- [38] Simulation tools using EMR libraries [On-line], [https://emr-website.univ-lille.fr/simulation/Consulted in April 2023](https://emr-website.univ-lille.fr/simulation/Consulted%20in%20April%202023).
- [39] C. Husar, M. Grovu, C. Irimia, A. Desrevaux, A. Bouscayrol, M. Ponchant, P. Magnin, "Comparison of Energetic Macroscopic Representation and structural representation on EV simulation under Simcenter Amesim", in *IEEE-VPPC'19*, Hanoi (Vietnam), October 2019.
- [40] I. Pintaric, S. Costa, A. Genic, D. Zuber, R. German, A. Bouscayrol, F. Tournez, "Flexible HiL Interface Implementation for Automotive XiL Testing", in *IEEE-VPPC'21*, Gijon (Spain), October 2021.
- [41] R. German, F. Tournez, A. Bouscayrol, A. Lièvre, B. Lemaire-Semail, "Power Hardware-In-the-Loop test of low-voltage battery for a plug-in hybrid electric vehicle", *EPE'22 ECCE Europe*, Hanover (Germany), September 2022.
- [42] "Grid Emulator (GE+ AC&DC), Installation and operation manual V11," Cinergia Power Solution, Barcelona., Spain, 2019, pp. 1-121.



Ronan German obtained his PhD from the University Lyon 1, France, in 2013. Since 2015 he has been an associate professor at the L2EP Lab of University of Lille. His current research axes include energy storage systems, energy management and power HiL testing.



Theodoros Kalogiannis obtained his master degree in 2015 from AAU, Denmark (Wind Power Systems field). Since 2017, he has been a scientific assistant on battery tests. at MOBI group of Vrije University of Brussels, on electrical modelling and pack design of battery cells for P-HEVs and BEVs.



Alain Bouscayrol received a Ph.D. degree in Electrical Engineering from the Institut National Polytechnique de Toulouse, France, in 1995. From 1996 he is at the L2EP Lab at University of Lille where he became full professor in 2005. His research interests deals with graphical descriptions for control of electrified vehicles and HiL testing.



Jiacheng He obtained his master's degree in electromechanical engineering from Southwest University, Chongqing, China, in 2018. He joined the MOBI team of Vrije University of Brussels as a PhD student in 2018. His PhD research topic is about battery thermal management.

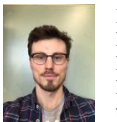

Florian Tournez obtained his master degree from University of Lille, France, in 2016. Since 2016 he is a research engineer at the Electrified Vehicle platform of the L2EP Lab at University of Lille. Since 2019, his PhD research topic is about power HiL testing for various electrified vehicle subsystems.



Maitane Berecibar obtained her PhD in Engineering of Sciences at the Vrije University of Brussels, Belgium, in 2017 in collaboration with the Technology Research Centre Ikerlan, Spain. Since 2019, Prof Berecibar is the Head of the Battery Innovation Center in the MOBI group of Vrije University of Brussels. Her researches are focused on various battery aspects (standardization, tests...)



Calin Husar received is PhD degree from University of Brasov, Romania, in 2008. Since 2009 he works for Siemens Industry Software Romania. His area of interest includes autonomous driving, electric and hybrid vehicles.

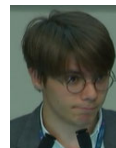

Marius Ciocan received a bachelor degree in computer science in Brasov, Romania in 2020. Since 2021 he is a software developer at Siemens Industrial Software.



Sergio Costa obtained his Master's degree in Sustainable Energy Technology from Technical University of Eindhoven, Netherlands. He has over 4 years of experience in R&D project management in electrification and renewable energy applications. He is currently working as a Technical Content Writer for Typhoon HiL

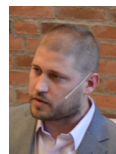

Adrien Genic received his Master degree in Electrical Engineering in 2011 at University of Novi Sad, Serbia. He has more than 10 year experience in real-time simulation and hardware-in-the-loop simulation in the field of power electronics and microgrids. He is currently a Modeling Team Lead in Typhoon HiL.



Betty Lemaire-Semail received the Ph.D. degree from University of Paris XI, Orsay, France, in 1990. She is currently a full professor and the head of the L2EP lab of University of Lille since 2015. Her main field of interest deals with the modeling and control of electrical systems, including piezoelectric actuators for positioning and force feedback.